

Operator Manual

EC SENSOR

INSTALLATION & MAINTENANCE



Revision G - 24/04/2008

EXCELLENCE IN PROCESS ANALYTICS

Product Recycling Information



ENGLISH

Electrical equipment marked with this symbol may not be disposed of in European public disposal systems after 12 August 2005. In conformity with European local and national regulations (EU Directive 2002/96/EC), European electrical equipment users must now return old or end-of-life equipment to the manufacturer for disposal at no charge to the user.

Note: For return for recycling, please contact the equipment manufacturer or supplier for instructions on how to return end-of-life equipment for proper disposal.

DEUTSCH

Elektrogeräte, die mit diesem Symbol gekennzeichnet sind, dürfen in Europa nach dem 12. August 2005 nicht mehr über die öffentliche Abfallentsorgung entsorgt werden. In Übereinstimmung mit lokalen und nationalen europäischen Bestimmungen (EU-Richtlinie 2002/96/EC), müssen Benutzer von Elektrogeräten in Europa ab diesem Zeitpunkt alte bzw. zu verschrottende Geräte zur Entsorgung kostenfrei an den Hersteller zurückgeben.

Hinweis: Bitte wenden Sie sich an den Hersteller bzw. an den Händler, von dem Sie das Gerät bezogen haben, um Informationen zur Rückgabe des Altgeräts zur ordnungsgemäßen Entsorgung zu erhalten.

FRANCAIS

A partir du 12 août 2005, il est interdit de mettre au rebut le matériel électrique marqué de ce symbole par les voies habituelles de déchetterie publique. Conformément à la réglementation européenne (directive UE 2002/96/EC), les utilisateurs de matériel électrique en Europe doivent désormais retourner le matériel usé ou périmé au fabricant pour élimination, sans frais pour l'utilisateur.

Remarque: Veuillez vous adresser au fabricant ou au fournisseur du matériel pour les instructions de retour du matériel usé ou périmé aux fins d'élimination conforme.

ITALIANO

Le apparecchiature elettriche con apposto questo simbolo non possono essere smaltite nelle discariche pubbliche europee successivamente al 12 agosto 2005. In conformità alle normative europee locali e nazionali (Direttiva UE 2002/96/EC), gli utilizzatori europei di apparecchiature elettriche devono restituire al produttore le apparecchiature vecchie o a fine vita per lo smaltimento senza alcun costo a carico dell'utilizzatore.

Nota: Per conoscere le modalità di restituzione delle apparecchiature a fine vita da riciclare, contattare il produttore o il fornitore dell'apparecchiatura per un corretto smaltimento.

DANSK

Elektriske apparater, der er mærket med dette symbol, må ikke bortskaffes i europæiske offentlige affaldssystemer efter den 12. august 2005. I henhold til europæiske lokale og nationale regler (EU-direktiv 2002/96/EF) skal europæiske brugere af elektriske apparater nu returnere gamle eller udtjente apparater til producenten med henblik på bortskaffelse uden omkostninger for brugeren.

Bemærk: I forbindelse med returnering til genbrug skal du kontakte producenten eller leverandøren af apparatet for at få instruktioner om, hvordan udtjente apparater bortskaffes korrekt.

SVENSKA

Elektronikutrustning som är märkt med denna symbol kanske inte kan lämnas in på europeiska offentliga sopsstationer efter 2005-08-12. Enligt europeiska lokala och nationella föreskrifter (EU-direktiv 2002/96/EC) måste användare av elektronikutrustning i Europa nu återlämna gammal eller uttrangerad utrustning till tillverkaren för kassering utan kostnad för användaren.

Obs! Om du ska återlämna utrustning för återvinning ska du kontakta tillverkaren av utrustningen eller återförsäljaren för att få anvisningar om hur du återlämnar kasserad utrustning för att den ska bortskaffas på rätt sätt.

ESPAÑOL

A partir del 12 de agosto de 2005, los equipos eléctricos que lleven este símbolo no deberán ser desechados en los puntos limpios europeos. De conformidad con las normativas europeas locales y nacionales (Directiva de la UE 2002/96/EC), a partir de esa fecha, los usuarios europeos de equipos eléctricos deberán devolver los equipos usados u obsoletos al fabricante de los mismos para su reciclado, sin coste alguno para el usuario.

Nota: Sírvase ponerse en contacto con el fabricante o proveedor de los equipos para solicitar instrucciones sobre cómo devolver los equipos obsoletos para su correcto reciclado.

NEDERLANDS

Elektrische apparatuur die is voorzien van dit symbool mag na 12 augustus 2005 niet meer worden afgevoerd naar Europese openbare afvalsystemen. Conform Europese lokale en nationale wetgeving (EU-richtlijn 2002/96/EC) dienen gebruikers van elektrische apparaten voortaan hun oude of afgedankte apparatuur kosteloos voor recycling of vernietiging naar de producent terug te brengen.

Nota: Als u apparatuur voor recycling terugbrengt, moet u contact opnemen met de producent of leverancier voor instructies voor het terugbrengen van de afgedankte apparatuur voor een juiste verwerking.

POLSKI

Sprzęt elektryczny oznaczony takim symbolem nie może być likwidowany w europejskich systemach utylizacji po dniu 12 sierpnia 2005. Zgodnie z europejskimi, lokalnymi i państwowymi przepisami prawa (Dyrektywa Unii Europejskiej 2002/96/EC), użytkownicy sprzętu elektrycznego w Europie muszą obecnie przekazywać Producentowi stary sprzęt lub sprzęt po okresie użytkowania do bezpłatnej utylizacji.

Uwaga: Aby przekazać sprzęt do recyklingu, należy zwrócić się do producenta lub dostawcy sprzętu w celu uzyskania instrukcji dotyczących procedur przekazywania do utylizacji sprzętu po okresie użytkowania.

PORTUGUES

Qualquer equipamento eléctrico que ostente este símbolo não poderá ser eliminado através dos sistemas públicos europeus de tratamento de resíduos sólidos a partir de 12 de Agosto de 2005. De acordo com as normas locais e europeias (Directiva Europeia 2002/96/EC), os utilizadores europeus de equipamentos eléctricos deverão agora devolver os seus equipamentos velhos ou em fim de vida ao produtor para o respectivo tratamento sem quaisquer custos para o utilizador.

Nota: No que toca à devolução para reciclagem, por favor, contacte o produtor ou fornecedor do equipamento para instruções de devolução de equipamento em fim de vida para a sua correcta eliminação.

Product Disposal

Note:

The following only applies to European customers.

Hach Ultra is committed to ensuring that the risk of any environmental damage or pollution caused by any of its products is minimized as far as possible. The European Waste Electrical and Electronic Equipment (WEEE) Directive (2002/96/EC) that came into force on August 13 2005 aims to reduce the waste arising from electrical and electronic equipment; and improve the environmental performance of all those involved in the life cycle of electrical and electronic equipment.



In conformity with European local and national regulations (EU Directive 2002/96/EC stated above), electrical equipment marked with the above symbol may not be disposed of in European public disposal systems after 12 August 2005.

Hach Ultra will offer to take back (**free of charge to the customer**) any old, unserviceable or redundant analyzers and systems which carry the above symbol, and which were originally supplied by Hach Ultra. Hach Ultra will then be responsible for the disposal of this equipment.

In addition, Hach Ultra will offer to take back (**at cost to the customer**) any old, unserviceable or redundant analyzers and systems which do not carry the above symbol, but which were originally supplied by Hach Ultra. Hach Ultra will then be responsible for the disposal of this equipment.

Should you wish to arrange for the disposal of any piece of equipment originally supplied by Hach Ultra, please contact your supplier or our After Sales Service department in Geneva for instructions on how to return this equipment for proper disposal.

Restriction of Hazardous Substances (RoHS)

The European Union RoHS Directive and subsequent regulations introduced in member states and other countries limits the use of six hazardous substances used in the manufacturing of electrical and electronic equipment.

Currently, monitoring and control instruments do not fall within the scope of the RoHS Directive, however Hach Ultra has taken the decision to adopt the recommendations in the Directive as the target for all future product design and component purchasing.



This product is compliant with the European Union RoHS Directive.

Note:

The following only applies to exports of this product into the People's Republic of China.

标记



含有有毒或者危险物质及成分的产品。

环保使用期限标记（年）

部件名称	有毒或者危险物质和成分					
	铅	汞	镉	六价铬	多溴联苯	多溴联苯醚
Connector socket	X					
Central tube	X					

O: 表示所有此类部件的材料中所含有毒或危险物质低于限制要求
 X: 表示至少有一种此类部件材料中所含有毒或危险物质高于限制要求

Table of Contents

1 Introduction

1.1	What You Have Received	5
1.1.1	An Oxygen, Ozone, or Hydrogen Electrochemical Sensor....	5
1.1.2	A Sensor Maintenance Kit.....	5
1.2	Basic Principle of Operation	5

2 Installation

2.1	Initial Sensor Cell Cleaning	9
2.2	Positioning Information	9
2.3	Sensor Insertion	10
2.4	Sensor Removal	10

3 Mounting Accessories

3.1	External Pressure Sensor.....	11
3.2	Weld-On Stainless Steel Socket.....	11
3.3	ProAcc™ Insertion/Extraction Valve.....	12
3.4	Orbisphere Flow Chambers.....	13
3.5	Multi Parameter Flow Chamber.....	15

4 Maintenance

4.1	Disassembly and Assembly.....	17
4.1.1	Taking the Sensor Apart (Membrane Removal).....	17
4.1.2	Sensor Assembly (Membrane Installation).....	18
4.2	Electrochemical Cleaning and Regeneration Center.....	22
4.3	Chemical Cleaning: Oxygen and Ozone Sensor Cell.....	23
4.3.1	Membrane Support Cleaning.....	23
4.3.2	Electrodes Ammonia Cleaning	24
4.3.3	Anode and Cathode Nitric Acid Cleaning	24
4.3.4	Sensor Face Polishing.....	25
4.3.5	O ₃ Sensor Only: Final Center Electrode Cleaning	26
4.4	Hydrogen Sensor Cell Cleaning	27

5 Troubleshooting

5.1	Electrochemical Oxygen Sensor	29
5.2	Electrochemical Ozone Sensor	30
5.3	Electrochemical Hydrogen Sensor	30

6 Technical Specifications

6.1	Orbisphere Electrochemical Sensor Design.....	31
6.2	Electrochemical Sensor Dimensions	31
6.3	EC Sensors and Parts Used on Orbisphere Configured Systems	32
6.4	Sensor Membrane Specifications.....	33
6.4.1	Oxygen Sensors (Table 1).....	33
6.4.2	Oxygen Sensors (Table 2).....	34

6.4.3	Hydrogen sensors.....	35
6.4.4	Ozone Sensors	36

7 Spare Parts

7.1	Electrochemical Sensor Parts.....	37
7.2	Accessories	37
7.3	Flow Chambers and Installation Devices.....	37
7.4	Protection Caps and Related Part Kits	39
7.5	Maintenance Kits for Electrochemical Sensors	40
7.5.1	Kits for O ₂ Sensors	40
7.5.2	Kits for O ₃ Sensors	41
7.5.3	Kits for H ₂ Sensors	41

Manual Overview

About this Manual

The information in this manual has been carefully checked and is believed to be accurate. However, Hach Ultra assumes no responsibility for any inaccuracies that may be contained in this manual. In no event will Hach Ultra be liable for direct, indirect, special, incidental, or consequential damages resulting from any defect or omission in this manual, even if advised of the possibility of such damages. In the interest of continued product development, Hach Ultra reserves the right to make improvements in this manual and the products it describes at any time, without notice or obligation.

Published in Europe.

Copyright © 2007 by Hach Ultra. All rights reserved. No part of the contents of this manual may be reproduced or transmitted in any form or by any means without the written permission of Hach Ultra.

Revision History

- Initial Release, August 1999, Orbisphere
- Revision A, May 2001, Orbisphere
- Revision B, February 2003, Hach Ultra Analytics
- Revision C, January 2004, Hach Ultra Analytics
- Revision D, February 2006, Hach Ultra
- Revision E, March 2007, Hach Ultra
- Revision F, May 2007, Hach Ultra
- Revision G, April 2008, Hach Ultra

Safety Precautions

Please read the entire manual before unpacking, setting up, or operating this sensor.

Pay particular attention to all warning and caution statements. Failure to do so could result in serious injury to the operator or damage to the equipment.

To ensure the protection provided by this equipment is not impaired, do not use or install this equipment in any manner other than that which is specified in this manual.

Safety Conventions



WARNING

A warning is used to indicate a condition which, if not met, could cause serious personal injury and/or death. Do not move beyond a warning until all conditions have been met.

CAUTION:





A caution is used to indicate a condition which, if not met, could cause minor or moderate personal injury and/or damage to the equipment. Do not move beyond a caution until all conditions have been met.

Note:

A note is used to indicate important information or instructions that should be considered before operating the equipment.

Precautionary Labels

Read all labels and tags attached to the sensor. Personal injury or damage to the sensor could occur if not observed.

	<p>This symbol, when noted on the product, indicates the presence of devices sensitive to electrostatic discharge and indicates that care must be taken to prevent damage to them.</p>
	<p>This symbol, when noted on the product, identifies a risk of chemical harm and indicates that only individuals qualified and trained to work with chemicals should handle chemicals or perform maintenance on chemical delivery systems associated with the equipment.</p>
	<p>Electrical equipment marked with this symbol may not be disposed of in European public disposal systems. In conformity with European local and national regulations, European electrical equipment users must now return old or end-of-life equipment to the manufacturer for disposal at no charge to the user.</p>
	<p>Products marked with this symbol indicates that the product contains toxic or hazardous substances or elements. The number inside the symbol indicates the environmental protection use period in years.</p>

Service and Repairs

None of the sensor's components can be serviced by the user. Only personnel from Hach Ultra or its approved representative(s) is (are) authorized to attempt repairs to the sensor and only components formally approved by the manufacturer should be used. Any attempt at repairing the sensor in contravention of these principles could cause damage to the sensor and corporal injury to the person carrying out the repair. It renders the warranty null and void and could compromise the correct working of the sensor and the electrical integrity or the CE compliance of the sensor.

If you have any problems with installation, or using the sensor please contact the company that sold it to you. If this is not possible, or if the results of this approach are not satisfactory, please contact the manufacturer's Customer Service.

Acknowledgements

- Dacron, Delrin, Tedlar, Tefzel, and Viton are registered trademarks of DuPont.
- Halar is a registered trademark of Ausimont U.S.A., Inc.
- Hastelloy is a registered trademark of Haynes International.
- Kynar is a registered trademark of The Pennwalt Corporation.
- Monel is a registered trademark of IMCO Alloys International, Inc.
- Saran is a registered trademark of Dow Chemical Co.
- Swagelok is a registered trademark of Swagelok Co.
- Microsoft and Windows are registered trademarks of Microsoft Corporation.

1 Introduction

1.1 What You Have Received

Check that all mounting hardware is included. Note that, unless the sensor is part of Orbisphere equipment that includes it, the sensor must be installed in an Orbisphere socket or flow chamber that allows contact with the sample flow to be analyzed (refer to “Installation” on page 9 for details).

1.1.1 An Oxygen, Ozone, or Hydrogen Electrochemical Sensor

The sensor head is protected by a screw-on plastic storage cap. A plastic screw-on base protects the connection socket, and provides at the same time a suitable stand.

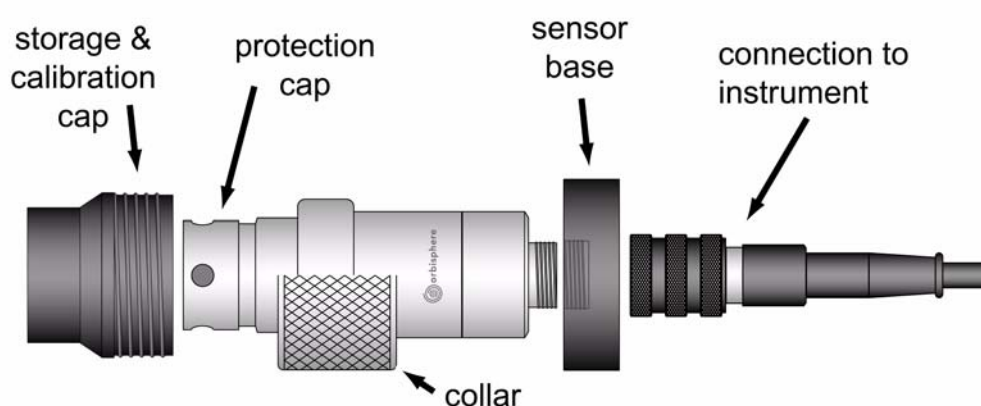

Fig 1-1: Electrochemical Sensor Components

1.1.2 A Sensor Maintenance Kit

The kit includes the material needed to maintain the sensor, including consumables, hardware, membrane removal and installation tools, plus a polishing device.

1.2 Basic Principle of Operation

In its simplest form, an electrochemical cell consists of a metal anode and a metal cathode dipped into an electrolyte solution contacting these electrodes. An electronic circuit is linked to the anode and cathode. Through an applied voltage, current will flow between the anode and the cathode.

The sensor is designed with one center electrode (cathode) and one counter electrode (anode) immersed in an electrolytic solution. The electrodes and the electrolyte are separated from the gaseous or liquid sample by a membrane permeable to gas.

Note:

Anode and cathode positions are inverted on the H₂ sensor

Additionally, the sensor's design includes a guard ring electrode which surrounds the sensor's center electrode. Its role is to reduce the influence of other gases on the center electrode, improving analysis stability.

The sensor head is covered with a protection cap and, in some applications, a grille to protect the membrane. Materials used for the components of the sensors differ with the application.

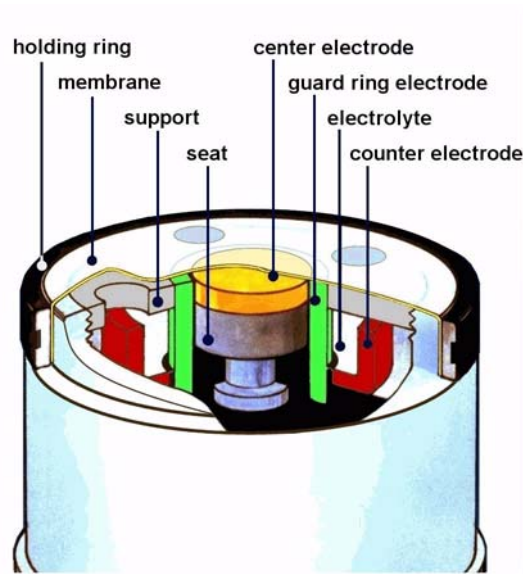

Fig 1-2: Sensor Cell Components

Gas penetrating through the membrane into the cell dissolves in the electrolyte. It undergoes a reaction at the cathode, causing a measurable electric current to flow. This current is proportional to the amount of gas entering the cell. The amount of gas entering the cell is proportional to the partial pressure of this gas in the sample, outside the cell.

The result is shown as gas concentration, which can then be displayed with a choice of several measuring units, according to instrument setup.

The sensor electronics perform four functions:

- Apply constant voltage to the anode
- Measure the current flowing through the sensor
- Compensate for temperature variation in the gaseous or liquid sample
- Convert the cell's electric current into an analog signal for sensor output



Fig 1-3: Electrochemical Sensor Overview



Fig 1-4: Electrochemical Sensors

2 Installation

2.1 Initial Sensor Cell Cleaning

Your Orbisphere electrochemical sensor has been thoroughly cleaned and tested at the factory. To protect the electrodes from oxidation, the cell has been filled with electrolyte and a membrane has been installed.

However, shipping and storage conditions can adversely affect electrochemical sensor cells, therefore a sensor service (cell cleaning & membrane replacement) must be performed before using the sensor.

To perform a sensor service, see the instructions in the section entitled “[Maintenance](#)” on [page 17](#). If you are not familiar with sensor servicing, your Hach Ultra representative will be glad to assist you.

Note:

Electrochemical H₂ sensors do not require a complete cleaning procedure, as dechloridization and rechloridization processes are normally not required.

2.2 Positioning Information

Unless the sensor is part of the Orbisphere equipment that includes it, the sensor must be installed in an Orbisphere socket or flow chamber, that allows the contact with the sample fluid to be analyzed.

The sensor and measuring instrument are connected by a cable and two 10 pin connectors. The standard sensor cable length is 3 meters, but extension cables of up to 1'000 m. are available, still retaining the same signal sensitivity. (If the model 28117 pressure sensor is used, the maximum cable length is 50 m.)

Check that the sensor will be mounted:

- perpendicular to the pipe.
- horizontal.
- on a horizontal pipe section (or on flow-ascending vertical pipe).
- min. 15 meters away from pump's discharge side.
- in a place where sample flow is stable and rapid; as far as possible from:
 - valves
 - pipe bends
 - suction side of pumps
 - CO₂ injection system or similar

Note:

There may be situations where not all the above conditions can be met. Please consult your Hach Ultra representative to appraise the situation and define the best applicable solution.

2.3 Sensor Insertion

- Insert the sensor straight into the flow chamber or socket.
- Hand tighten the attaching collar.
- Connect the sensor cable.
- Check for leaks; replace O-rings if product leaks are visible.

Micro Volume Flow Chambers:

Do not twist the sensor when inserting it into a micro volume flow chamber. This rotation may twist the membrane holding ring, thus changing the membrane position. This can modify the membrane measuring conditions, and affect measurement precision.

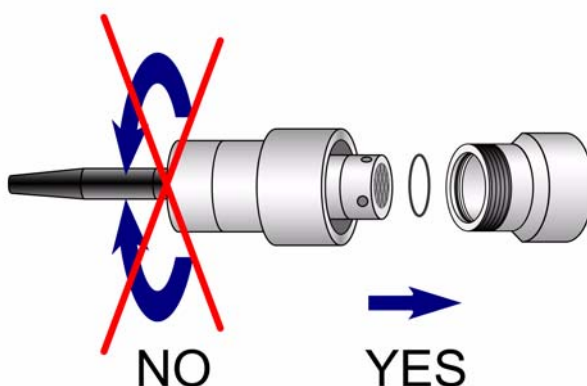

Fig 2-1: Sensor Insertion

Note:

Check that the small O-ring at the bottom of the flow chamber is present during removal and installation of the sensor, as it may stick to the sensor head and fall.

2.4 Sensor Removal

- Shut off the sample flow and drain the sampling circuit of liquid or gas.
- Remove the sensor cable connected at the sensor end.
- Hold the sensor body in one hand to avoid rotation and unscrew the collar with the other hand.
- Pull the sensor straight out of the socket or flow chamber.
- Check that both O-rings remain in place inside the flow chambers.
- Install sensor storage cap and sensor base (to protect the connection).

3 Mounting Accessories

Note:

Check the spare part list at the end of this manual for ordering information.

3.1 External Pressure Sensor

The system can be fitted with an external pressure sensor. This enables a measurement of fraction of gas under variable pressure conditions during gas phase measurement.



Two models are available, depending on application:

- 28117 Pressure sensor 0 - 5 bar absolute
- 28117C Pressure sensor 0 - 1 bar absolute

CAUTION:

Do NOT exceed the pressure range of the sensor. This would permanently deform the sensor membrane, thus delivering incorrect pressure values in the future.

The external sensor connects to the Orbisphere measuring equipment with a 1 meter cable and a 4 pin connector (an optional extension cable can be used, but total length should not exceed 50 m.).

The external pressure sensor can be installed in the 32002.xxx multi parameter flow chamber. It is held in place by a blue threaded collar. Tightness is assured by the O-ring on the sensor seat.

3.2 Weld-On Stainless Steel Socket

The 29501 weld-on sensor socket can be used to install a sensor into a stainless steel pipe (min. \varnothing 50 mm or 2"). When welding the socket to the pipe, check that setback between the pipe's inner diameter and the sensor tip does not exceed 4 mm (see diagram).

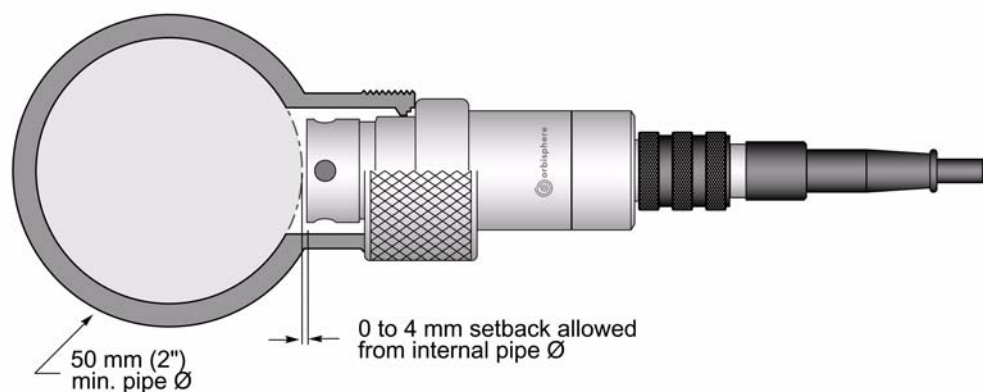

Fig 3-1: Weld-On Sensor Socket

Note:

Be sure to remove the two O-rings from the socket before welding. Leave the sensor's stainless steel cap screwed on during welding to prevent thread distortion.

Recommendation:

To facilitate sensor removal and installation, we suggest installing the socket in a location where the liquid can be drained quickly and easily. By creating a one meter long piece of pipe (shown below) with shut off valves at both ends, just a small volume of liquid needs to be drained to enable sensor removal. Also, a precise sensor and socket installation can be performed in the workshop, and this assembly can be placed in the production line with minimal down time.

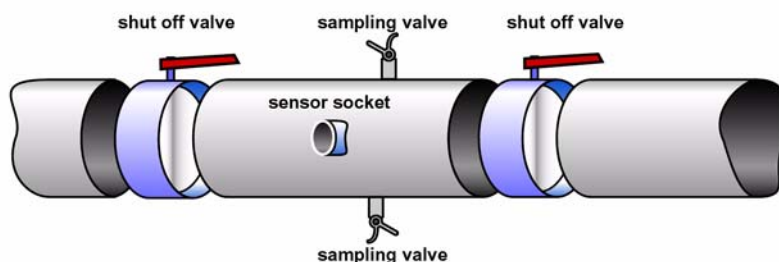

Fig 3-2: Installation In-Line

3.3 ProAcc™ Insertion/Extraction Valve

The Orbisphere 32003 insertion/extraction valve allows for sensor removal and installation without having to drain the fluid in the line. It can withstand a pressure of up to 20 bars, with the sensor in place or not. This device is held in place by a stainless steel clamp to a Tuchenhagen Varivent® In-Line Access Unit.

Sensor insertion is done by aligning the sensor with the valve and tightening the retaining collar until it stops. Removal is done by unscrewing the collar and pulling the sensor out.



Tuchenhagen Varivent® In-Line Access Unit

Purchasing a Tuchenhagen Varivent® In-Line Access Unit, or an equivalent fitting with a 68mm flange diameter from the fitting manufacturer is required to make use of the 32003 ProAcc Valve.

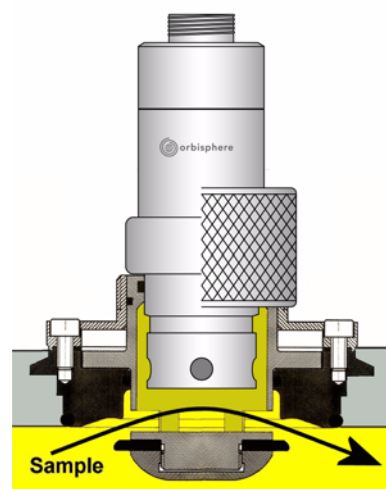
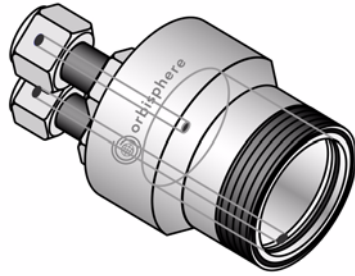

Fig 3-3: ProAcc™ Insertion/Extraction Valve

3.4 Orbisphere Flow Chambers

The Orbisphere 32001. xxx flow chambers are used to draw liquid and gaseous samples past the sensor. They are available in several materials, depending on the application.

They connect to 6-mm or ¼" stainless steel tubing by means of two Swagelok™ fittings. If necessary, copper or plastic tubing with low permeability can be substituted. Stainless steel tubing is normally enough to hold the assembly in place, but for a more stable installation, a large U-bolt can be used to mount the flow chamber to a support.



Dimensions of sensor and flow chamber assembly :

- Width: 50 mm
 - Height: 210 mm
- (add 100 mm for connection length)

Table 3-1: Flow Chamber Orientation

Sample	Orientation of flow chamber	
Gaseous or liquid media	Vertically, with connections down and sensor up - Center connection is the inlet - Outer connection is the outlet	
Gaseous media, with occasional liquid or vapor	Horizontally, to allow for drainage - Center connection (inlet) must be up - Outer connection (outlet) must be down	

The connection diagram below is a recommended installation that allows for measuring and calibrating without having to disconnect a line manually. "A" and "B" represent 3-way valves.

For measuring, calibration gas inlets and outlets are shut off. During calibration, the flow is reversed to drive the remaining sample out. The calibration gas enters at the "sample out" port and exits at the "sample in" port, as shown.

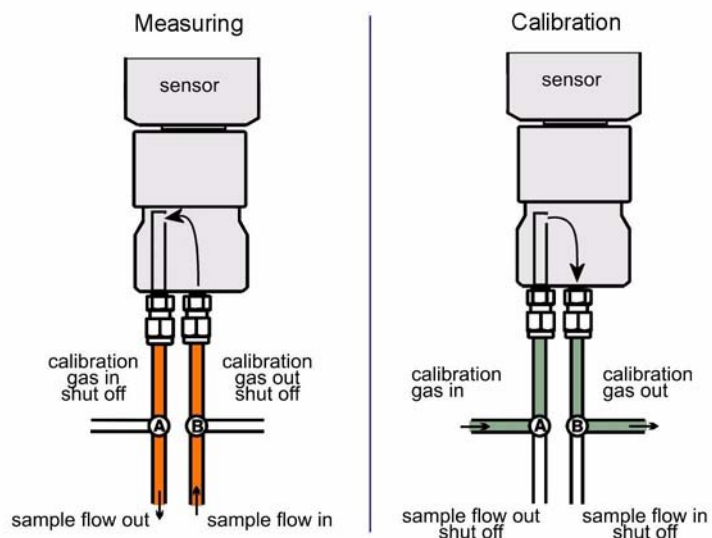

Fig 3-4: Flow Chamber Connections

3.5 Multi Parameter Flow Chamber

Note:

Suitable only for gaseous media.

The Orbisphere 32002.xxx multi parameter flow chamber can accommodate one or two sensors and one sample pressure sensor. If only one gas sensor is used, the unused socket is plugged with the stainless steel plugs provided (model 28123). The flow chamber is connected to 6 mm or ¼" stainless steel tubing by two Swagelok™ fittings. If necessary, copper or plastic tubing with a very low permeability can be substituted.

The flow chamber should be mounted in such a way that the sample outlet port is located at the lowest point to allow condensation to escape with the outgoing gas. Attach the flow chamber to a vertical support with the screws supplied. The pressure sensor must be on top.

Note:

A user manufactured spacer (~15 mm thick) may be used between the flow chamber and support for improved access for sensor removal.

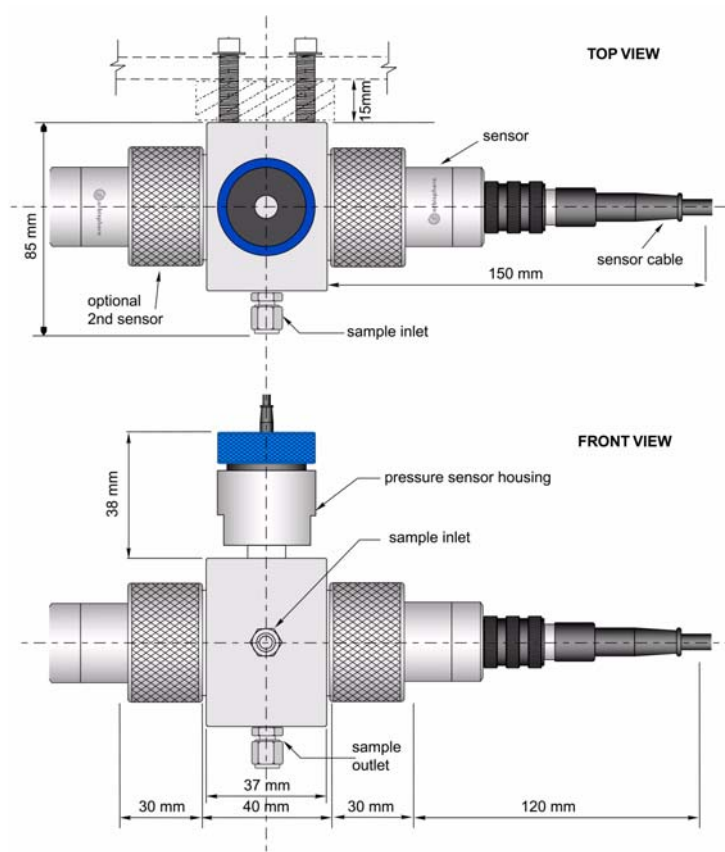

Fig 3-5: 32002.xxx Multi Parameter Flow Chamber

Shown here with:

- gas sensor (right),
- pressure sensor (center),
- optional second sensor (left)

4 Maintenance

4.1 Disassembly and Assembly

4.1.1 Taking the Sensor Apart (Membrane Removal)

It is important to install the electrochemical sensor standing on its base. This base offers good protection for the delicate connector socket, at the same time providing a suitable work stand.



Remove the plastic storage cap.

Unscrew the protection cap, using the tool provided in the maintenance kit.



Pay attention to the components inside the protection cap. Note the assembly order of each item (see protection cap application tables in [“Protection Caps and Related Part Kits”](#) on page 39).

Note:

The illustration on the right is an example only. Your configuration may differ.

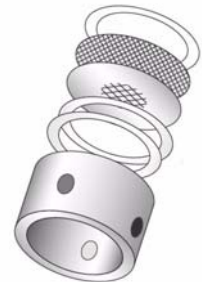

Pull up the attaching ring with the tool provided in the maintenance kit.



Remove the membrane and mask (if applicable).

Drain the electrolyte into a sink and rinse the sensor cavity with tap water.

CAUTION:

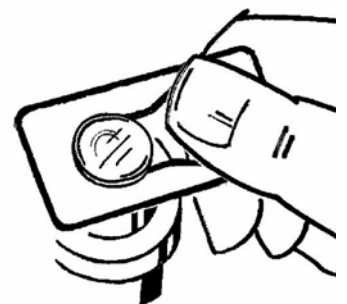

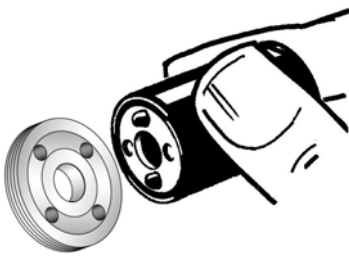
Avoid eye or skin contact with electrolyte which can be slightly corrosive.



	<p>Insert the prongs of the membrane support removal tool into the membrane support holes, and unscrew the membrane support.</p>	
<p>Note: <i>The membrane support is individually machined and paired with the sensor. For correct sensor operation, it is ESSENTIAL to keep a membrane support with its respective sensor. Should the membrane support require replacement, contact your Hach Ultra representative.</i></p>		

4.1.2 Sensor Assembly (Membrane Installation)

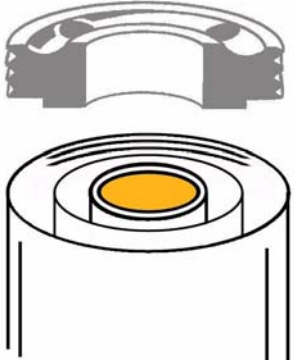
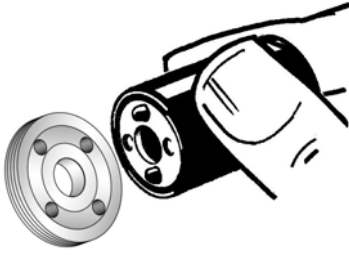
Before starting the sensor reassembly, proceed to the sensor maintenance section for anode and cathode cleaning instructions.

<p>Install the membrane support with the groove on the upper side.</p> <p>Note: <i>The membrane support is individually machined and paired with the sensor. Therefore make sure that the correct membrane support is used on the correct sensor.</i></p>	<p>This side up</p> 	
	<p>Insert the prongs of the membrane support removal tool into the membrane support holes.</p> <p>Tighten the membrane support finger tight.</p>	
<p>CAUTION: <i>Too much torque will damage the sensor electrodes.</i></p>		

The membrane mounting surface must be clean and even.

Replace the membrane O-ring on the sensor head with a new one.

Note:

The 29039.4 Nitril O-ring can be reused if it is still in good condition. Membrane O-rings are part of the protection cap kit.



For the correct electrolyte selection, please refer to the table in [“Electrochemical Sensor Parts” on page 37](#).

Using the syringe or bottle nozzle included in the maintenance kit, fill up the sensor cavity with electrolyte.

Note:

Be careful not to touch the electrodes with the needle, as a scratch on the surface may lead to loss of performance.

Tilt the sensor slightly and inject into the lower hole, pushing bubbles out at the upper hole. Gently tap on the sensor side to move trapped bubbles.

Return the sensor to the vertical position. The last drop of electrolyte should form a cupola on top of the sensor tip.

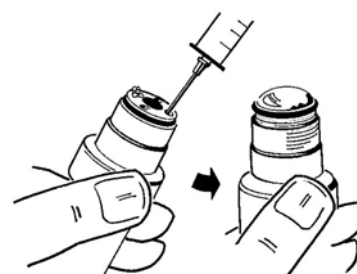

In the maintenance kit, pick up the two part membrane mounting tool.

Install the sleeve over the sensor head (end with shoulder downwards).

Note:

Once installed, a membrane cannot be reused. Avoid touching the membrane with bare fingers, as this may affect its sensitivity.



Take a few membranes out of the storage box.

Using tweezers included in the kit, pick up one membrane of the stack, and gently place it on the sensor tip.

Make sure it is centered, and no bubble is trapped.

If a sensor mask is used, place it directly on top of the membrane.

For correct membrane selection, please refer to the tables in [“Sensor Membrane Specifications” on page 33](#).



Note:

Distinguish the membrane from the protection paper:

- *The membrane is transparent (translucent).*
- *The protection paper is opaque.*

The membrane diameter is larger than sensor head diameter. This is normal, as the membrane will fold over the sensor tip.

The membrane holding ring comes in two slightly different internal diameters, depending on the membrane(s) total thickness.

For a correct membrane installation, be sure to use the correct holding ring for the application.



29228 holding ring :
membrane thickness < 50 μ

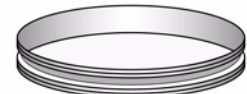

29229 holding ring :
membrane(s) total thickness ≥ 50 μ

Place the membrane holding ring on the installation tool tip.

CAUTION:

To avoid damaging the membrane, make sure that the tool tip is totally clean and its surface is even.

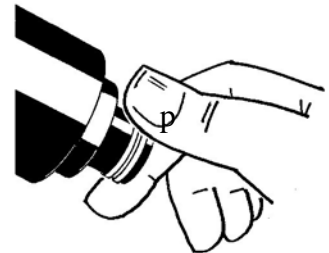

Insert the installation tool inside the guiding sleeve.



Push the installation tool firmly downwards. This clasps the mounting ring onto the sensor head, folding the membrane over the sensor tip.

Remove the installation tool and guiding sleeve.

Visually check for correct ring placement, try to push it down with your fingers.

Check that the membrane is tight, with no wrinkles, and no bubbles are present.

Rinse the sensor with tap water and wipe dry with a clean cloth.

Check for electrolyte leaks.

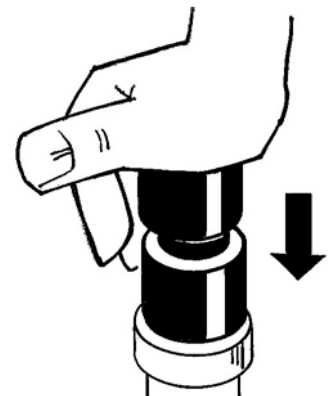

Prepare the protection cap for installation:

Replace all the parts inside the protection cap with new ones (except the grille), and place them in the order they were removed.

The Tefzel washers, under the cap, should be slightly lubricated with silicone grease.

Note:

The illustration on the right is an example only. Your configuration may differ.

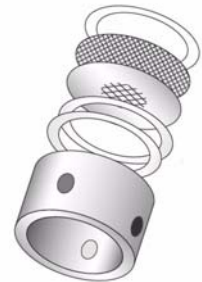

Tighten the protection cap finger tight.

Then, complete the process using the tool provided in the maintenance kit. Insert into each of the four holes in turn, and tighten as far as possible. Tighten each hole only once.

Note:

The grille inside the protection cap should be free to move during tightening. Therefore, and to avoid damage to the membrane, do not touch the grille during the tightening process.

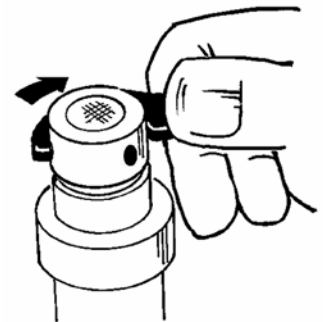

Always store the sensor with the storage cap and base installed.

Put a few drops of clean water in the storage cap to prevent the sensor cell drying.

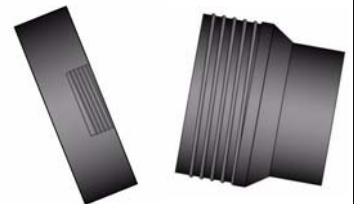

Note:

A sensor that has been taken apart or serviced must always be calibrated. Allow the sensor to settle for 30 minutes, before performing the sensor calibration.

4.2 Electrochemical Cleaning and Regeneration Center

The Orbisphere 32301 is a very efficient cleaning and regeneration tool for Orbisphere electrochemical sensors. This tool reverses the electrochemical process that is taking place in the sensor cell during normal operation. This removes oxidation and at the same time regenerates the electrodes' surface. In addition, the regeneration center offers a continuity tester for checking the sensor electronics.

Use of this tool is recommended because the regeneration of the electrodes allows for a noticeably extended sensor life.

Detailed information on how to use the Orbisphere 32301 cleaning and regeneration center is included in the related Operator's Manual.



Fig 4-1: Model 32301 Cleaning and Regeneration Center

Note:

It is mandatory to use the 32301 Sensor Cleaning and Regeneration Center for servicing electrochemical H₂ sensors. This process is called dechloridization and rechloridization of the electrodes. See “Hydrogen Sensor Cell Cleaning” on page 27.

4.3 Chemical Cleaning: Oxygen and Ozone Sensor Cell

(Not applicable for H₂ sensors). The following supposes that the sensor has been taken apart. For disassembly and assembly procedures, see “Disassembly and Assembly” on page 17.

Conditions

Wear on the membrane, and chemical reactions within the sensor, requires that the sensor be serviced regularly to restore its original sensitivity. Service includes electrode cleaning and membrane replacement. A clear sign that a sensor maintenance is required is when measurements are noticeably less stable than usual, and when a calibration does not improve the situation.

Method description (see following step-by-step procedure)

- Electrochemical cleaning with 32301 (if available)

... when not available or results are insufficient:

- Anode and cathode chemical cleaning
- Central electrode polishing
- Final rinsing

Note:

To eliminate any silver residue that ammonia cleaning cannot remove, it is sometimes required to repeat the chemical cleaning using nitric acid (HNO₃, not over 70% by weight).

4.3.1 Membrane Support Cleaning

Empty and rinse the electrolyte reservoir under tap water.

Rinse membrane support under water and wipe it dry.

Check for the presence of any residue on the surfaces.

Residue can be removed by placing the support in a container of nitric acid (HNO₃, not over 70% by weight) until it recovers its original appearance (normally within 30 seconds)

Rinse one minute under tap water and check again for surface cleanliness.

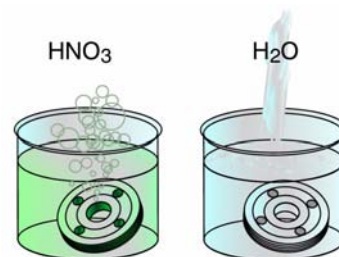

CAUTION:

Nitric acid is dangerous! Please refer to the safety information from your chemical supplier.

4.3.2 Electrodes Ammonia Cleaning

Fill the sensor electrolyte reservoir with a solution of 25% by weight ammonium hydroxide (NH_4OH) in water and leave for 10 minutes.

Rinse with tap water for at least one minute.

Inspect the sensor head. The counter electrode should be a silver-white color.

If the counter electrode still shows deposits, repeat the procedure.



CAUTION:

Ammonia is dangerous! Please refer to the safety information from your chemical supplier.

4.3.3 Anode and Cathode Nitric Acid Cleaning

Check for the absence of silver deposit on the central guard ring electrode walls, as such deposits can make contact with the counter electrode.

To eliminate any silver residue inside the sensor cell, it is sometimes required to repeat the chemical cleaning using nitric acid (HNO_3 , not over 70% by weight).

Also, the 32301 electrochemical cleaning does not remove deposit on the cell's plastic parts, so nitric acid cleaning may be required.



Note:

This procedure is not recommended for normal maintenance, and should not be used more often than twice a year, as the acid degrades the metal of the counter electrode, thus reducing the sensor's life.

Place concentrated nitric acid into the sensor electrolyte reservoir, and add 1 drop on the center electrode.

Leave for no longer than 3 seconds.

Quickly empty the acid and rinse thoroughly under tap water for one minute.



CAUTION:

Nitric acid is dangerous! Please refer to the safety information from your chemical supplier.

4.3.4 Sensor Face Polishing

Once the sensor has been cleaned, the face of the center electrode must be polished together with the membrane support.

Note:

Install the membrane support with the groove on the upper side. The membrane support is individually machined and paired with the sensor. Therefore make sure that the correct membrane support is used on the correct sensor.

This side up

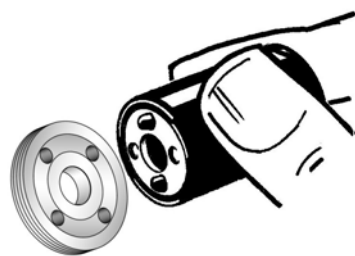
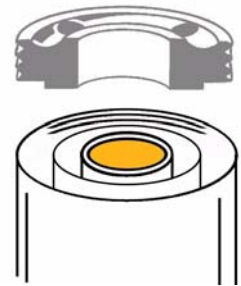

Insert the prongs of the membrane support removal tool into the membrane support holes.

Tighten the membrane support finger tight.

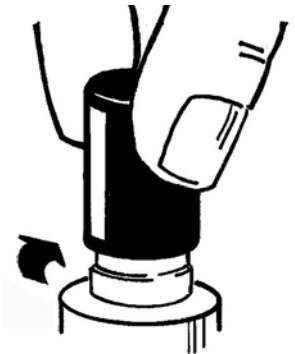

CAUTION:

Too much torque will damage the sensor electrodes

Place the dish with the polishing cloth on a flat surface.

Spread a little polishing powder onto the cloth.

Mix with a few drops of water to get a grey, milky liquid.

Make sure to use the correct polishing powder for your application. See the spare parts tables in ["Spare Parts" on page 37](#).

Note:

Use one polishing cloth per sensor model, to prevent a possible contamination through metal particle transfer.



Holding the sensor vertically, and using a circular motion, polish the sensor face for at least 30 seconds, until the electrodes are clean and shiny.

This step may need to be repeated several times.

Make sure to avoid skin contact with the polishing cloth; it should be kept free of dust and grease.



Remove the membrane support with installation tool.

Rinse the support and sensor cavity with a strong jet of clean water.

Use distilled water if the water quality is doubtful.



Carefully inspect that the tiny groove between the center electrode and the guard ring electrode is totally clean and free of polishing residue.

Clean only with a strong water spray. The edge of a paper sheet can be used to remove sticking residue.



4.3.5 O₃ Sensor Only: Final Center Electrode Cleaning

Once the O₃ sensor has been successfully cleaned and polished, a final nitric acid treatment should be applied, as follows:

Place the sensor in a vertical position on its base.

Fill the electrolyte reservoir with a few drops of water, just enough to cover the outer electrode. The center electrode must be kept dry.

Place a drop of nitric acid on the center electrode, covering only the electrode and guard ring. Avoid spilling acid into the water.

Wait less than a minute, then rinse thoroughly under tap water.

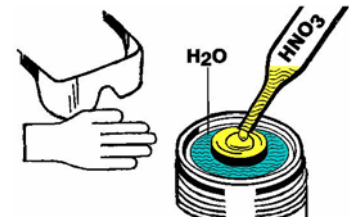

CAUTION:

Nitric acid is dangerous! Please refer to the safety information from your chemical supplier

4.4 Hydrogen Sensor Cell Cleaning

Conditions

The hydrogen analyzer works on the principle that hydrogen molecules, passing through the membrane, generate an electric current at the platinum anode surface. For this to take place, an extremely clean metal surface is essential. If any film, grease or other impurity covers the platinum surface, the reaction is impeded and may even be stopped.

In addition, the chemical reaction that takes place on the chloridized silver cathode leads to loss of performance after a certain operation time.

As a result, a sensor service must be carried out to restore its original performance.

Method

The procedure for cleaning the H₂ electrochemical sensor requires the use of the Orbisphere 32301 Sensor Cleaning and Regeneration Center. This procedure is explained in detail in the 32301 Operator's Manual.

As an overview, H₂ electrochemical sensor cleaning consists of the following sequence of operations :

- Dechloridization of the cathode: This process removes the chloride film from the silver cathode surface (carried out by the Orbisphere 32301).
- Rechloridization of the cathode: A layer of silver chloride is grown on the cathode's surface (carried out by the Orbisphere 32301).
- Activation of the platinum anode: The center anode surface is polished, and treated with nitric acid.

5 Troubleshooting

5.1 Electrochemical Oxygen Sensor

Table 5-1: Troubleshooting - Oxygen Sensor

Problem	Probable Cause	Possible Solution
Sensor won't calibrate, even after thorough servicing.	Repeated calibrations go beyond "expected limits" of instrument.	MOCA 3600 only: Select membrane from "Options/Membrane" menu. Then, calibrate the sensor.
	Instrument internal barometric pressure sensor needs calibration.	Calibrate "Barom. Pressure" menu. Check against a certified barometer. Do not correct for sea level !
	Wet membrane interface.	Wipe dry with a tissue and re-calibrate.
	"H ₂ S insensitivity" option enabled.	Disable from the "Options/Gas" menu on the measuring instrument.
"0000" O ₂ levels displayed.	Wrong reading scale "XXXX" selected for display unit.	Change reading scale by selecting "X.XXX, XX.XX or XXX.X" from. "Options/Display Units" menu.
Shorter than expected sensor operation in relatively high dissolved O ₂ concentration.	High O ₂ concentrations generate deposits more quickly.	Install a less permeable membrane. Turn off the analyzer when sensor is not in a low O ₂ concentration.
Unexpected or inaccurate dissolved O ₂ readings.	Air leak on product sample line.	Set flow rate to 100 ml/min. Wait until stable, then slowly double this flow rate. The stable value of dissolved O ₂ reading must be the same as before. A variation related to flow rate is a clear sign of an air leak in the line.
	High residual current.	Place sensor in de-aerated sample; wait for low reading; Check concentration against low measurement limit (see tables in " Sensor Membrane Specifications " on page 33). If concentration is significantly higher than low limit, try a sensor service.

5.2 Electrochemical Ozone Sensor

When the O₃ sensor has been properly calibrated using the Orbisphere measuring instrument, the sensor has to settle down for up to 24 hours when used in very low O₃ concentration conditions.

Table 5-2: Troubleshooting - Ozone Sensor

Problem	Probable Cause	Possible Solution
Sensor won't calibrate, even after thorough servicing.	Repeated calibrations go beyond "expected limits" of instrument.	MOCA 3600 only: Select membrane from "Options/Membrane" menu. Then, calibrate the sensor. O ₃ sensor cleaned with HNO ₃
	Instrument internal barometric pressure sensor needs calibration.	Calibrate "Barom. Pressure" menu. Check against a certified barometer. Do not correct for sea level !
	Wet membrane interface.	Wipe dry with a tissue and re-calibrate.
"0000" O ₃ levels displayed.	Wrong reading scale "XXXX" selected for display unit.	Change reading scale by selecting "X.XXX, XX.XX or XXX.X" from "Options/Display Units" menu.
Unexpected/incorrect dissolved O ₃ reading.	High residual current.	If concentration is significantly higher than low limit, try a sensor service.
	Insufficient flow rate.	Regulate flow equivalent to membrane specified levels.
	Length of sample line allows O ₃ time to react.	Reduce length of sample tubing.
	Doesn't match lab samples.	Take samples at close proximity to sensor.

5.3 Electrochemical Hydrogen Sensor

Table 5-3: Troubleshooting - Hydrogen Sensor

Problem	Probable Cause	Possible Solution
Sensor won't calibrate, even after thorough servicing.	Repeated calibrations go beyond "expected limits" of instrument.	MOCA 3600 only: Select membrane from "Options/Membrane" menu. Then, calibrate the sensor.
"0000" H ₂ levels displayed.	Wrong reading scale "XXXX" selected for display unit.	Change reading scale by selecting "X.XXX, XX.XX or XXX.X" from "Options/Display Units" menu.
Shorter-than-expected sensor operation (in relatively high H ₂).	High H ₂ concentrations require more work from electrochemical sensor.	Shut off analyzer when not needed.
Unexpected/incorrect H ₂ readings.	High residual current.	If concentration is significantly higher than low limit, try a sensor service.

6 Technical Specifications

6.1 Orbisphere Electrochemical Sensor Design

Table 6-1: Specifications - Sensor Design

Gas	Max. Press Rating (bar)	Sensor Models	Comments
O ₂	20	31 11x.yz	Where : x = Sensor special characteristics (0 to 6 ; depending on application) y = Membrane O-ring material (0 = EDPM / 1 = Viton / 2 = Kalrez / 4 = Nitril) z = Head material (1=St Steel / 2=Peek / 4=Hastelloy / 5=Titanium / 7= Monel) Suffixes (when used) : A denotes a sensor with fast response to temp. change E denotes an EEx certified sensor (Ex-Proof) s denotes a Smart sensor, used on Multi analyzer
	50	31 12x.yz	
	100	31 13x.yz	
	200	31 14x.yz	
O ₃	20	31 31x.yz	
	100	31 33x.yz	
H ₂	50	31 21x.yz	
	100	31 23x.yz	
	200	31 24x.yz	

- All Orbisphere electrochemical sensors' enclosures are certified IP68 / NEMA4
- PEEK (Polyetheretherketone) is a highly crystalline thermoplastic

6.2 Electrochemical Sensor Dimensions

Electrochemical sensor weight is from 140 to 700 grams, depending on the construction material.

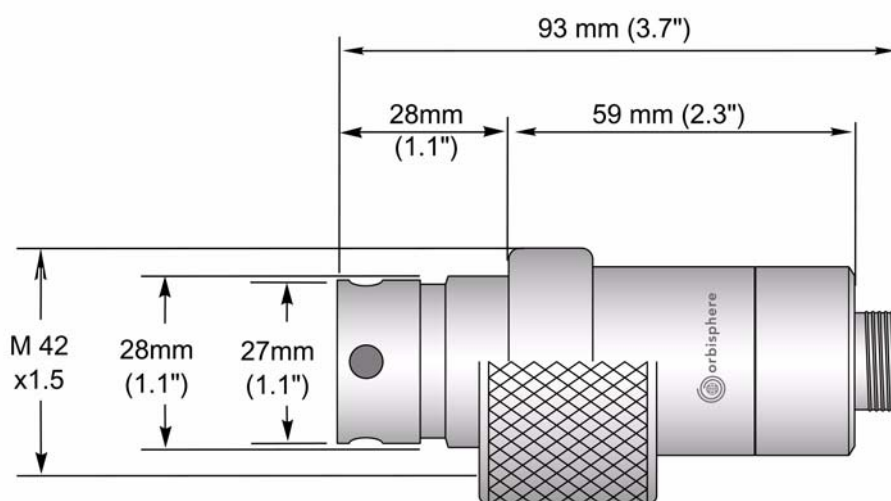

Fig 6-1: Sensor Dimensions

6.3 EC Sensors and Parts Used on Orbisphere Configured Systems

Table 6-2: Specifications - Orbisphere Configured Systems

Configured System	Sensor	Membrane	Protection Cap	Protection Cap Kit	Maintenance Kit
Package analyzer 3625	31 110.02	2956A	29111 (as used on TC sensors)	28002 Tefzel washers only	32703
ProBrix 3624	31 110.02	2952A	29104.0	29054	32702
Pharmapack 29981	31 110A.02	2956A + one Goretex® membrane ref. 32918	None	Not applicable	32703 + 32918 (10 piece box)

6.4 Sensor Membrane Specifications

6.4.1 Oxygen Sensors (Table 1)

Table 6-3: Membrane Specifications - Oxygen Sensors (1)

Membrane Model	2956A	2958A	29552A	2952A
Recommended applications	Corrosion control, De-aerated water	Beverage, Lab. applications	In line wort, Air/O ₂ injection, Sewage treatment	Corrosion control, In line beverage, De-aerated water
Material	PFA	Tefzel®	PTFE	Tefzel®
Thickness [µm]	25	12.5	50	25
Calibration gas	Air	Air	Air	Air / Pure O ₂
Dissolved measurement range	0 ppb to 20 ppm	0 ppb to 40 ppm	0 ppb to 80 ppm	0 ppb to 80 ppm
Gaseous measurement range	0 Pa to 50 kPa	0 Pa to 100 kPa	0 Pa to 200 kPa	0 Pa to 200 kPa
Accuracy	The greater of ±1% of reading or ± 0.1 ppb ¹ , or ± 1 ppb ² , or ± 0.25 Pa	The greater of ±1% of reading or ± 1 ppb, or ± 2 Pa	The greater of ±1% of reading or ± 2 ppb, or ± 5 Pa	The greater of ±1% of reading or ± 2 ppb, or ± 5 Pa
	¹ Accuracy is ± 0.1 ppb for 410, 510, 362x, 360x and 3655 instruments ² Accuracy is ± 1 ppb for 366x and 3650 instruments			
Integrated radiation dose limit [rads]	2 x 10 ⁴	10 ⁸	N/A	10 ⁸
Expected current in air @ 1 bar 25°C [µA]	26.4	9.4	6.3	5.4
Expected current in pure O ₂ [µA]	132	47	31.4	27
O ₂ consumption in O ₂ saturated water at 25°C [µg/hour]	40	14	9.4	8
Temp. compensation range	- 5 to 60° C			
Temp. measuring range	- 5 to 100° C			
Response time ¹	7.2 sec.	9.5 sec.	90 sec.	38 sec.
Recommended min. liquid flow rate ² [mL/min]	180	120	50	50
Recommended min. linear flow rate ² [cm/sec]	200	100	30	30
Recommended gaseous flow rate [L/min]	0.1 to 3			

6.4.2 Oxygen Sensors (Table 2)

Table 6-4: Membrane Specifications - Oxygen Sensors (2)

Membrane Model	2935A	29521A	2995A
Recommended applications	Saturated to super saturated levels	Saturated to super saturated levels	In line hot wort (up to 70°C)
Material	Halar®	Tefzel®	Tedlar®
Thickness [µm]	25	125	12.5
Calibration gas	Air / Pure O ₂	Air / Pure O ₂	Pure O ₂
Dissolved measurement range	0 ppb to 400 ppm	0 ppb to 400 ppm	0 ppb to 2000 ppm
Gaseous measurement range	0 Pa to 1000 kPa	0 Pa to 1000 kPa	0 Pa to 5000 kPa
Accuracy	The greater of ±1% of reading or ± 10 ppb, or ± 20 Pa	The greater of ±1% of reading or ± 10 ppb, or ± 20 Pa	The greater of ±1% of reading or ± 50 ppb, or ± 100 Pa
Integrated radiation dose limit [rads]	N/A	10 ⁸	10 ⁸
Expected current in air @ 1 bar 25°C [µA]	0.9	0.7	0.2
Expected current in pure O ₂ [µA]	4.7	3.8	0.9
O ₂ consumption in O ₂ saturated water at 25°C [µg/hour]	1.4	1.3	0.3
Temp. compensation range	- 5 to 60° C		
Temp. measuring range	- 5 to 100° C		
Response time ¹	2.5 min.	18 min.	80 sec.
Recommended min. liquid flow rate ² [mL/min]	25	25	5
Recommended min. linear flow rate ² [cm/sec]	20	60	5
Recommended gaseous flow rate [L/min]	0.1 to 3		

6.4.3 Hydrogen sensors

Table 6-5: Membrane Specifications - Hydrogen Sensors

Membrane Model	2956A	2952A	2995A	29015A
Recommended applications	Trace measurement	Low concentration	Average concentration	High concentration
Material	PFA	Tefzel®	Tedlar®	Saran
Thickness [µm]	25	25	12.5	23
Calibration gas	1% pure H ₂	10% pure H ₂	100% pure H ₂	100% pure H ₂
Dissolved measurement range	0 ppb to 75 ppb	0 ppb to 300 ppb	0 ppb to 3200 ppb	0 ppb to 32 ppm
Gaseous measurement range	0 Pa to 5 kPa	0 Pa to 20 kPa	0 Pa to 200 kPa	0 kPa to 2000 kPa
Accuracy	The greater of ±1% of reading or ± 0.03 ppb, or ± 1 Pa	The greater of ±1% of reading or ± 0.09 ppb, or ± 6 Pa	The greater of ±1% of reading or ± 1 ppb, or ± 50 Pa	The greater of ±1% of reading or ± 10 ppb, or ± 1 kPa
Integrated radiation dose limit	2 x 10 ⁴	10 ⁸	10 ⁸	N/A
Expected current in air @ 1 bar 25°C [µA]	N/A			
Expected current in pure gas [µA]	150	50	5	0.5
Temp. compensation range	0 to 50°C	0 to 50°C	10 to 45°C	10 to 45 °C
Temp. measuring range	-5 to 100° C			
Response time ¹	2 sec.	5 sec.	6 sec.	50 sec.
Recommended min. liquid flow rate ² [mL/min]	50 to 220	40 to 200	20 to 70	20 to 40
Recommended min. linear flow rate ² [cm/sec]	200	150	50	30
Recommended gaseous flow rate [L/min]	0.005 to 3			

6.4.4 Ozone Sensors

Table 6-6: Membrane Specifications - Ozone Sensors

Membrane Model	2956A	29552A
Recommended applications	Trace measurement	High concentration (> 1 mg/l)
Material	PFA	PTFE
Thickness [μm]	25	50
Calibration gas	Span gas or air	
Dissolved measurement range	0 ppb to 50 ppm	0 ppb to 200 ppm
Gaseous measurement range	0 Pa to 10 kPa	0 Pa to 40 kPa
Accuracy	The greater of $\pm 1\%$ of reading ($\pm 5\%$ for sensors calibrated in air) or ± 5 ppb, or ± 1 Pa	The greater of $\pm 1\%$ of reading ($\pm 5\%$ for sensors calibrated in air) or ± 20 ppb, or ± 4 Pa
Integrated radiation dose limit	2×10^4	N/A
Expected current in air @ 1 bar 25°C [μA]	26.4	6.5
Expected current in pure gas [μA]	105	31.4
Temp. compensation range	-5 to 45° C	
Temp. measuring range	-5 to 100° C	
Response time ¹	30 sec.	6 min.
Recommended min. liquid flow rate ² [mL/min]	350 ³	100 ³
Recommended min. linear flow rate ² [cm/sec]	30	10
Recommended gaseous flow rate [L/min]	0.01 to 3	

1. Response time at 25 °C for a 90% signal change
2. Liquid flow through an Orbisphere 32001 flow chamber, with protection cap and no grille
3. These flow rates take into account the decomposition of ozone in the tubing between the line and the flow chamber (theoretical flow rates in the absence of decomposition would be 10 times less)

7 Spare Parts

7.1 Electrochemical Sensor Parts

Table 7-1: Sensor Spare Parts

Part N°	Description
28114	Membrane support mounting tool
28129	Delrin storage cap (sensor's storage cap)
28614	Combined protection cap and membrane holding ring removal tool
29010	Electrolyte for H ₂ sensor (50 ml)
29011	Chloridizing solution for H ₂ sensor (50 ml)
2959	Electrolyte for oxygen sensor (50 ml)
2961	Electrolyte for H ₂ insensitive oxygen sensor (50 ml)
2969	Electrolyte for ozone sensor (50 ml)
2978	Polishing kit, including 0.05 µm powder (2933) and cloth - suitable for O ₂ sensors
29781	Polishing kit, including 3µm powder (29331) and cloth - for O ₃ and H ₂ sensors
32205	Sensor support (base) for 31xxx sensors
32920	Membrane mounting tool, including centering sleeve and plunger

7.2 Accessories

Table 7-2: Sensor Accessories

Part N°	Description
28117	Pressure sensor, 0-5 bar absolute
28117.C	Pressure sensor, 0-1 bar absolute
29006.0	EPDM O-rings for flow chamber/sensor socket 28x2 and 32x2mm

7.3 Flow Chambers and Installation Devices

Table 7-3: Flow Chambers and Installation Devices

Part N°	Description
29501.0	Sensor socket for welding to SS pipe, with EPDM O-ring
29501.1	Sensor socket for welding to SS pipe, with Viton O-ring
29508	Multi parameter flow chamber for headspace piercing device
32001.010	Flow chamber in stainless steel (316) with 6 mm fittings. Supplied with EPDM O-rings.
32001.011	Flow chamber in stainless steel (316) with ¼" fittings. Supplied with EPDM O-rings.

Table 7-3: Flow Chambers and Installation Devices

Part N°	Description
32001.030	Flow chamber in Delrin with 6 mm fittings. Supplied with EPDM O-rings.
32001.031	Flow chamber in Delrin with ¼" fittings. Supplied with EPDM O-rings.
32001.0N1	Flow chamber in Inconel with ¼" fittings. Supplied with EPDM O-rings.
32001.141	Flow chamber in Hastelloy with ¼" fittings. Supplied with Viton O-rings.
32001.151	Flow chamber in titanium with ¼" fittings (6 mm fittings not available in titanium) Supplied with Viton O-rings.
32001.181	Flow chamber in Kynar with ¼" fittings. Supplied with Viton O-rings.
32001.191	Flow chamber in PTFE with ¼" fittings. Supplied with Viton O-rings.
32001.030	Flow chamber, Delrin, 6 mm fittings, EPDM O-rings
32001.031	Flow chamber, Delrin, ¼ in. fittings, EPDM O-rings
32002.010	Multi parameter flow chamber in stainless steel with 6 mm fittings. Supplied with EPDM O-rings.
32002.011	Multi parameter flow chamber in stainless steel with ¼" fittings. Supplied with EPDM O-rings.
32003	ProAcc sensor insertion device ; for use with Tuchenhagen adapter
32006	Flow chamber in stainless steel (316) for use with for model 28117 and 28117.C pressure sensors.
32007D	Flow chamber in Delrin for the power logger (3655), with one meter of tubing.
32007E.110	Flow chamber in stainless steel (316) with 6 mm fittings for use with 3650Ex. Supplied with Viton O-rings.
32007E.111	Flow chamber in stainless steel (316) with ¼" fittings for use with 3650Ex. Supplied with Viton O-rings.
32007F	Flow chamber in Delrin for the micrologger (3650). Includes check valve, 1 meter of inlet tubing, quarter turn flow valve, and outlet metal U-tube (6mm outside diameter). (replaces 32007B)
32007W.030	Flow chamber in Delrin with 6 mm stainless steel Swagelok fittings for use with liquids with suspended particles. Supplied with EPDM O-rings.
32007W.031	Flow chamber in Delrin with ¼" stainless steel Swagelok fittings for use with liquids with suspended particles. Supplied with EPDM O-rings.
32009	Flow chamber in acrylic with 1/8" Swagelok fittings for small volume liquid phase measurements using 311XX sensors.
32011	Flow chamber in acrylic with 1/8" Swagelok fittings for small volume liquid phase measurements, with port for 32562 external temperature sensor.
32013	Flow chamber in PEEK, with spiral flow path for reduced flow demand for use with TC sensors for 3654 Micro logger. Supplied with check valve, 1 meter tubing, and needle valve.
32015.020	Flow chamber in PEEK with 6 mm Swagelok fittings, for use with H ₂ 3654 radiation resistant applications. With spiral flow path for reduced flow demand. Supplied with EPDM O-rings. No tubing supplied. Suitable for use up to 10 bar.
32015.021	Flow chamber in PEEK with ¼" Swagelok fittings, for use with H ₂ 3654 radiation resistant applications. With spiral flow path for reduced flow demand. Supplied with EPDM O-rings. No tubing supplied. Suitable for use up to 10 bar.
32017	Flow chamber used with 29981 Pharmapack. Must be ordered separately.

7.4 Protection Caps and Related Part Kits

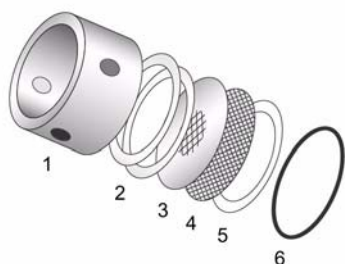

Protection cap, typical

- 1) Protection cap
- 2) Tefzel® washers
- 3) Grille
- 4) Dacron® (or Gore-Tex®) mesh
- 5) Silicon (or Viton®) washer
- 6) O-ring (membrane tightness)

Note:

Depending on the application, O-rings (membrane tightness) are available in EPDM, Viton®, Kalrez®, or Nitril®

Table 7-4: Protection Caps and Related Part Kits

Application	Ref.	Protection Cap	Ref.	Kit Includes:
Liquids And Dry Gases	29106.0	Protection cap for use in liquids & dry gases. Supplied with 29046.0 and EPDM O-rings.	29046.0	28002 Tefzel washer x 6 (2) 29060 St steel grille 0.2mm 29049 Dacron mesh x10 (1) 28003 Silicone washers x 3 (1) 29039.0 EPDM O-ring x 5 (1)
	29106.1	Protection cap for use in liquids and dry gases. Supplied with 29046.1 and Viton O-rings.	29046.1	28002 Tefzel washer x 6 (2) 29060 St steel grille 0.2mm 29049 Dacron mesh x10 (1) 28003 Silicone washers x 3 (1) 29039.1 Viton O-rings x 5 (1)
	29106.4	Protection cap for use in liquids and dry gases. Supplied with 29046.4 and Nitril O-rings.	29046.4	28002 Tefzel washer x 6 (2) 29060 St steel grille 0.2mm 29049 Dacron mesh x10 (1) 28003 Silicone washers x 3 (1) 29039.4 Nitril O-ring (1)
Standard	29104.0	Prot. cap without grille Supplied with 29054 and EPDM O-rings.	29054	28002 Tefzel washer x 6 (2) 28003 Silicone washers x 3 (1) 29039.0. EPDM O-ring x 5 (1)
	29104.15	Prot. cap in titanium. Supplied with 29054.1 and Viton O-rings.	29054.1	28002 Tefzel washer x 6 (2) 28508.1 Viton washer x (1) 29039.1 Viton O-rings x 5 (1)
	29104.25	Prot. cap in titanium Supplied with 29054.2 and Kalrez O-rings.	29054.2	28002 Tefzel washer x 6 28508.1 Viton washer (1) 29039.2 Kalrez O-ring x 1 (1)
Moist Gases	29107.0	Protection cap for use in moist gases. Supplied with 29063 and EPDM O-rings.	29063	28002 Tefzel washer x 6 (2) 29060 St steel grille 0.2mm 28003 Silicon washer x3 (1) 29031A Gore-Tex disc x3 (1) 29039.0 EPDM O-ring x5 (1)

7.5 Maintenance Kits for Electrochemical Sensors

The maintenance kit delivered with a new Orbisphere sensor includes enough consumables for several sensor services. Order additional consumable parts in order to keep this sensor maintenance kit complete. Please contact your Hach Ultra representative.

7.5.1 Kits for O₂ Sensors

Table 7-5: Kits for Oxygen Sensors

Part N°	Description
2980A	Kit for oxygen electrochemical sensors for H ₂ S insensitive applications. Includes membranes 2956A, electrolyte 2961, and tools for sensor maintenance.
32701	Kit for oxygen electrochemical sensors. Includes membranes 2935A, electrolyte 2959, membrane holding ring 29228, and tools for sensor maintenance.
32702	Kit for oxygen electrochemical sensors. Including membranes 2952A, electrolyte 2959, membrane holding ring 29228, and tools for sensor maintenance.
32702A	Kit for oxygen electrochemical sensors used with 365x instruments. Includes membranes 2952A, electrolyte 2959, membrane holding ring 29228, kit 29046, and tools for sensor maintenance.
32703	Kit for oxygen electrochemical sensors. Includes membranes 2956A, electrolyte 2959, membrane holding ring 29228, and tools for sensor maintenance.
32703A	Kit for oxygen electrochemical sensors used with 365x instruments. Includes membranes 2956A, electrolyte 2959, membrane holding ring 29228, kit 29046, and tools for sensor maintenance.
32704	Kit for oxygen electrochemical sensors. Includes membranes 2958A, electrolyte 2959, membrane holding ring 29228, and tools for sensor maintenance.
32704A	Kit for oxygen electrochemical sensors used with 365x instruments. Includes membranes 2958A, electrolyte 2959, membrane holding ring 29228, kit 29046, and tools for sensor maintenance.
32705	Kit for oxygen electrochemical sensors. Includes membranes 29521A, electrolyte 2959, membrane holding ring 29231, and tools for sensor maintenance.
32706	Kit for oxygen electrochemical sensors. Includes membranes 29552A, electrolyte 2959, membrane holding ring 29229, and tools for sensor maintenance. (Replaces 32706L & 32706M.)
32706A	Kit for oxygen electrochemical sensors used with 365X instruments. Includes membranes 29552A, electrolyte 2959, membrane holding ring 29229, kit 29046, and tools for sensor maintenance.
32707	Kit for oxygen electrochemical sensors. Includes membranes 2995A, electrolyte 2959, membrane holding ring 29228, and tools for sensor maintenance.
32711	Kit for oxygen electrochemical sensors. Includes membranes 2935A, electrolyte 2959, mask 29026A, membrane holding ring 29229, tools for sensor maintenance.
32712	Kit for oxygen electrochemical sensors. Includes membranes 2952A, electrolyte 2959, mask 29026A, membrane holding ring 29229, tools for sensor maintenance.
32713	Kit for oxygen electrochemical sensors. Includes membranes 2956A, electrolyte 2959, mask 29026A, membrane holding ring 29229, tools for sensor maintenance.
32713A	Kit for oxygen electrochemical sensors used with 365x instruments. Includes membranes 2956A, electrolyte 2959, mask 29026A, membrane holding ring 29229, kit 29046, and tools for sensor maintenance.

Table 7-5: Kits for Oxygen Sensors

Part N°	Description
32714	Kit for oxygen electrochemical sensors. Includes membranes 2958A, electrolyte 2959, mask 29026A, ring 29229, and tools for sensor maintenance.
32717	Kit for oxygen electrochemical sensors. Includes membranes 2995A, electrolyte 2959, mask 29026A, membrane holding ring 29229, tools for sensor maintenance.

7.5.2 Kits for O₃ Sensors

Table 7-6: Kits for Ozone Sensors

Part N°	Description
32731	Kit for ozone electrochemical sensors. Includes membranes 2956A, electrolyte 2969, mask 29027A, membrane holding ring 29229.05, and tools for sensor maintenance.
32732	Kit for electrochemical ozone sensors for use with 3660. Includes membranes 29552A, electrolyte 2969, membrane holding ring 29229.05, and tools for sensor maintenance. (Replaces 32732L.)

7.5.3 Kits for H₂ Sensors

Table 7-7: Kits for Hydrogen Sensors

Part N°	Description
32720	Kit for hydrogen electrochemical sensors. Includes membranes 2952A, electrolyte 29010, chloridizing solution 29011, membrane holding ring 29228, and tools for sensor maintenance.
32721	Kit for hydrogen electrochemical sensors. Includes membranes 29015A, electrolyte 29010, chloridizing solution 29011, membrane holding ring 29228, and tools for sensor maintenance.
32722	Kit for hydrogen electrochemical sensors. Includes membranes 2956A, electrolyte 29010, chloridizing solution 29011, membrane holding ring 29228, and tools for sensor maintenance.
32723	Kit for hydrogen electrochemical sensors. Includes membranes 2995A, electrolyte 29010, chloridizing solution 29011, membrane holding ring 29228, and tools for sensor maintenance.
32725	Kit for hydrogen electrochemical sensors. Includes membranes 2956A, electrolyte 29010, chloridizing solution 29011, mask 29026A, membrane holding ring 29229, and tools for sensor maintenance.
32726	Kit for hydrogen electrochemical sensors. Includes membranes 2995A, electrolyte 29010, chloridizing solution 29011, mask 29026A, membrane holding ring 29229, and tools for sensor maintenance.
32727	Kit for hydrogen electrochemical sensors. Includes membranes 2952A, electrolyte 29010, chloridizing solution 29011, mask 29026A, membrane holding ring 29229, and tools for sensor maintenance.

Annex

Tables and Illustrations

Fig. 1-1	Electrochemical Sensor Components	5
Fig. 1-2	Sensor Cell Components.....	6
Fig. 1-3	Electrochemical Sensor Overview.....	7
Fig. 1-4	Electrochemical Sensors	8
Fig. 2-1	Sensor Insertion	10
Fig. 3-1	Weld-On Sensor Socket.....	11
Fig. 3-2	Installation In-Line	12
Fig. 3-3	ProAcc™ Insertion/Extraction Valve.....	12
Table 3-1	Flow Chamber Orientation.....	13
Fig. 3-4	Flow Chamber Connections	14
Fig. 3-5	32002.xxx Multi Parameter Flow Chamber	15
Fig. 4-1	Model 32301 Cleaning and Regeneration Center	22
Table 5-1	Troubleshooting - Oxygen Sensor.....	29
Table 5-2	Troubleshooting - Ozone Sensor.....	30
Table 5-3	Troubleshooting - Hydrogen Sensor.....	30
Table 6-1	Specifications - Sensor Design.....	31
Fig. 6-1	Sensor Dimensions	31
Table 6-2	Specifications - Orbisphere Configured Systems	32
Table 6-3	Membrane Specifications - Oxygen Sensors (1).....	33
Table 6-4	Membrane Specifications - Oxygen Sensors (2).....	34
Table 6-5	Membrane Specifications - Hydrogen Sensors	35
Table 6-6	Membrane Specifications - Ozone Sensors	36
Table 7-1	Sensor Spare Parts	37
Table 7-2	Sensor Accessories.....	37
Table 7-3	Flow Chambers and Installation Devices	37
Table 7-4	Protection Caps and Related Part Kits	39
Table 7-5	Kits for Oxygen Sensors.....	40
Table 7-6	Kits for Ozone Sensors.....	41
Table 7-7	Kits for Hydrogen Sensors.....	41

Global Headquarters

6, route de Compois, C.P. 212,
1222 Vérenaz, Geneva, Switzerland

Tel ++ 41 (0)22 594 64 00

Fax ++ 41 (0)22 594 64 99

Americas Headquarters

481 California Avenue,
Grants Pass, Oregon 97526, USA

Tel 1 800 866 7889 / 1 541 472 6500

Fax 1 541 479 3057

www.hachultra.com

