

Operator Manual

ANATEL UP-100

LASER PARTICLE COUNTER



EXCELLENCE IN PROCESS ANALYTICS

Operator Manual

ANATEL UP-100

LASER PARTICLE COUNTER

Table of Contents

1	About the System	
1.1	Performance Specifications	7
1.2	Physical Specifications	7
1.3	Communication Details	8
1.4	Computer Connection	8
1.5	Typical Cleaning Requirements	8
1.6	Typical Operator Troubleshooting Requirements	8
2	Installation Procedures	
2.1	Inspection and Unpacking.....	9
2.2	Locating the Instrument	9
2.3	Standard Precautions	9
2.4	Device Familiarization.....	10
3	Operating Instructions	
3.1	Controls and Indicators	13
3.2	Pre-operating Procedures.....	14
3.3	Ultrapure-100 Analyzer Operation	16
3.4	Data Output Parameters for 4-20 mA	18
3.5	Reconfiguring Analyzer via Utility Program	18
3.6	Operator Maintenance	21
4	Remote Data Logging	
4.1	Data Table for Log Mode	24
4.2	Data Table for Linear Mode	25
5	Remote Control ASCII Commands	
5.1	Communications Protocol	27
5.2	Data Integrity.....	27
5.3	Autobaud Operation.....	27
5.4	Command Set.....	28
5.5	Peak Hold	29
6	Writing an Ultrapure-100 Serial Driver	
6.1	Initialization Sequence (After Power-up of the Ultrapure-100).....	31
7	Configuring CountSpec Software for Use with Ultrapure-100	

Appendix A: Service Procedures

A.1	Return Procedures.....	35
A.2	Technical Support Information.....	37

Appendix B: Particle Counter Technical Specifications

B.1	Laser Diode Characteristics.....	39
-----	----------------------------------	----

Appendix C: Good Sampling Practices

C.1	Using Tee Pieces.....	43
C.2	Using Multiport Valves	44
C.3	Using Regulators	44
C.4	Dead-legs.....	45

Manual Overview

About This Manual

The information in this manual has been carefully checked and is believed to be accurate. However, Hach Ultra Analytics assumes no responsibility for any inaccuracies that may be contained in this manual. In no event will Hach Ultra Analytics be liable for direct, indirect, special, incidental, or consequential damages resulting from any defect or omission in this manual, even if advised of the possibility of such damages. In the interest of continued product development, Hach Ultra Analytics reserves the right to make improvements in this manual and the products it describes at any time, without notice or obligation.

Published in the United States of America

Hach Ultra Analytics P/N: 701232 Edition 1, December 2003

Copyright © 2003 by Hach Ultra Analytics

All rights reserved. No part of the contents of this manual may be reproduced or transmitted in any form or by any means without the written permission of Hach Ultra Analytics.

Safety Conventions



WARNING

A warning is used to indicate a condition that, if not met, could cause serious personal injury and/or death. Do not move beyond a warning until all conditions have been met.

CAUTION:

A caution is used to indicate a condition that, if not met, could cause damage to the equipment. Do not proceed beyond a caution until all conditions have been met.

Note:

A note is used to indicate important information or instructions that should be considered before operating the equipment.

General Safety Considerations

- Only factory certified personnel should perform service on the Ultrapure-100.
- Make sure the Ultrapure-100 Particle Counter is properly installed and all hydraulic connections are correctly installed before operation. All safety guidelines should be observed when using high-pressure devices.
- Follow all procedures in [“Service Procedures” on page 35](#) before shipping a unit to a service center for repair or re-calibration.



WARNING

Attempts by untrained personnel to disassemble, alter, modify or adjust the electronics may result in personal injury and damage to the Ultrapure-100.

- Laser Safety — Class 1 Laser Product — complies with 21 CFR Chapter 1, Subchapter J.

**WARNING**

Use of controls or adjustments, or performance of procedures other than those specified herein may result in hazardous radiation exposure.

Warranty

Hach Ultra Analytics warrants this instrument to be free of defects in materials and workmanship for a period of one (1) year from the shipping date. If any instrument covered under this warranty proves defective during this period, Hach Ultra Analytics will, at its option, either repair the defective product without charge for parts and labor, or provide an equivalent replacement in exchange for the defective product.

To obtain service under this warranty, the customer must notify the nearest Hach Ultra Analytics service support center on or before the expiration of the warranty period and follow its instructions for return of the defective instrument. The customer is responsible for all costs associated with packaging and transporting the defective unit to the service support center, and must prepay all shipping charges. Hach Ultra Analytics will pay for return shipping if the shipment is to a location within the same country as the service support center.

This warranty shall not apply to any defect, failure, or damage caused by improper use or maintenance or by inadequate maintenance or care. This warranty shall not apply to damage resulting from attempts by personnel other than Hach Ultra Analytics representatives, or factory-authorized and trained personnel, to install, repair or service the instrument; to damage resulting from improper use or connection to incompatible equipment; or to instruments that have been modified or integrated with other products when the effect of such modification or integration materially increases the time or difficulty of servicing the instrument.

THIS WARRANTY IS GIVEN BY HACH ULTRA ANALYTICS WITH RESPECT TO THIS INSTRUMENT IN LIEU OF ANY OTHER WARRANTIES, EXPRESSED OR IMPLIED. HACH ULTRA ANALYTICS AND ITS VENDORS DISCLAIM ANY IMPLIED WARRANTIES OF MERCHANTABILITY OR FITNESS FOR A PARTICULAR NON-CONTRACTUAL PURPOSE. HACH ULTRA ANALYTICS' RESPONSIBILITY TO REPAIR OR REPLACE DEFECTIVE PRODUCTS IS THE SOLE AND EXCLUSIVE REMEDY PROVIDED TO THE CUSTOMER FOR BREACH OF THIS WARRANTY. HACH ULTRA ANALYTICS AND ITS VENDORS WILL NOT BE LIABLE FOR ANY INDIRECT, SPECIAL, INCIDENTAL, OR CONSEQUENTIAL DAMAGES EVEN IF HACH ULTRA ANALYTICS OR ITS VENDORS HAS BEEN GIVEN ADVANCED NOTICE OF THE POSSIBILITY OF SUCH DAMAGES.

Acknowledgements

- Anatel is a registered trademark of Hach Company.
- CIMScan is a registered trademark of CIMTechniques, Inc.
- Flare-Tek is a registered trademark of Fluoroware, Inc.
- Intel and Pentium are registered trademarks of the Intel Corporation.
- Kal-Rez is a registered trademark of DuPont Dow Elastomers, L.L.C.
- Kel-F is a registered trademark of 3M Company and/or its subsidiaries.
- Micro is a trademark or registered trademark of Electron Microscopy Sciences.
- Microsoft, Windows, Windows 2000, Windows XP, Windows 98 SE, Windows NT 4.0, Microsoft .NET are trademarks or registered trademarks of the Microsoft Corporation.

- Particle Vision Online, Particle Vision II, and CountSpec are trademarks or registered trademarks of Hach Ultra Analytics.
- Swagelok is a registered trademark of the Swagelok Company.
- Teflon is a registered trademark of E.I. du Pont de Nemours and Company.

1 About the System

The Anatel Ultrapure-100 Particle Counter is a compact 2-channel (4-channel optional) liquid particle counter designed for analysis of ultrapure water monitoring applications. It is built around a robust 0.1 μm liquid particle sensor. The analyzer uses a 4-20 mA analog current output as the primary means of transmitting particle count data to a data logging device, such as a PLC or SCADA system.

The Ultrapure-100 contains flow control, particle sensing, signal processing and analog output electronics as well as a microprocessor based command/control communications system all in one assembly. The Ultrapure-100 can be controlled remotely from a host computer via an RS-232 serial port (the protocol is factory set). The communications protocol used is either ASCII or SECS-II Standard. The factory default for the Ultrapure-100 is RS-232 communications with ASCII protocol. The Ultrapure-100 also features a local display to provide the current particle concentration normalized per milliliter.

1.1 Performance Specifications

Size Channels	<ul style="list-style-type: none"> • Two channels: 0.1 and 0.2 μm • Four channels: 0.1, 0.2, 0.5, and 1.0 μm
System Flow Rate	>1 L/min (>60 psig inlet pressure)
Sample Flow Rate	100 mL/min (regulated for inlet pressure between 30 and 100 psig)
Light Source	Laser Diode
Inlet Pressure	690 kPa maximum (100 psig), 48 kPa minimum (7.0 psig)
Operating and Sample Temperature	7°C to 40°C (41°F to 104°F)
Non-operating temperature limits	-40° to 71° C (-40° to 159.8° F)
Relative Humidity	90% maximum, non-condensing
Non-operating Humidity	98% maximum, non-condensing

1.2 Physical Specifications

Power Requirement	100 to 250 VAC, 50/60 Hz
Power Consumption	80 VA maximum (0.8 A at 100 V)
I/O Connections Analog	Opto-isolated 4-20 mA output (2 channels standard, 4 channels optional) RS-232 Serial connection for set up
Display	2 channels or 4 channels of particle count data (user selectable)
Indicators	<ul style="list-style-type: none"> • Power • Laser Condition • Leak Status

Fluid Connections	<ul style="list-style-type: none"> • SS ¼" Swagelok® (inlet and outlet) • External flowmeter
Enclosure Materials	Aluminum alodine with painted external finish
Dimensions	305 mm L x 203 mm W x 190.5 mm D (12" x 8" x 7.5")

1.3 Communication Details

The 4-20 mA outputs provide 2-channel (4-channel optional) analog data. An external mating plug to the 4-20 mA connector is provided beneath the removable base cover. The 4-20mA connector is located beside the serial (DB-9) connector. This plug allows the user to connect the Ultrapure-100 to external logging devices, such as PLC or SCADA systems, chart recorders, etc. The counter updates the 4-20mA analog signal output at the end of each counting period. The default sample period is 20 seconds. The sample time can be set using the set up utility software supplied with the Ultrapure-100. See also ["Writing an Ultrapure-100 Serial Driver" on page 31](#) for a full description of interfacing via the serial port.

1.4 Computer Connection

The Ultrapure-100 is equipped with a serial port used primarily for instrument configuration (It can also be used for data acquisition by a range of Hach Ultra Analytics' software packages; contact a sales representative for details). Users may also use the serial port for integrating the Ultrapure-100 to third party software packages. ["Remote Control ASCII Commands" on page 27](#) provides details of the Ultrapure-100's serial command set for producing drivers as necessary.

The computer may be any programmable system or device that has standard RS-422 or RS-232 serial communication capabilities. The RS-422 or RS-232 device can be a controlling computer or another computer-controlled device able to communicate with the Ultrapure-100 using the ASCII or SECS-II protocol. The counter provides particle count data updated at the end of each run.

1.5 Typical Cleaning Requirements

The external surfaces of the unit may be cleaned. Always turn the power off before cleaning. Use a lightly moistened lint-free cloth or a vacuum cleaner to clean the external surfaces.

CAUTION:

Do not use solvents, which may damage the display and flow meter components.

1.6 Typical Operator Troubleshooting Requirements

Operator troubleshooting is limited to verifying instrument connections and cleaning the particle sensors' flow cell. However, cleaning the flow cell is rarely required. Once the Ultrapure-100 is installed on a clean water system and is performing satisfactorily, cleaning should not be required between the six-month calibration cycles. ["Particle Counter Technical Specifications" on page 39](#) details pre-cleaning checks, as well as the actual cleaning procedure should this be required.

2 Installation Procedures

This section explains the installation of the Ultrapure-100 and its connection with external equipment. The documentation accompanying the external equipment should be consulted for the proper mechanical and electrical connection procedures for those devices. If necessary, consult a local service center to resolve any questions of compatibility or suitability of this product.

2.1 Inspection and Unpacking

The Ultrapure-100 is shipped in a single shipping carton. This carton should be retained for returning the unit to the factory.

Upon receipt, visually inspect for signs of external shipping damage. Damage to the contents should be brought to the attention of the shipper.

Verify all materials received in the ship kit against the shipping papers to assure receipt of all materials. Missing items should be brought to the attention of a Hach Ultra Analytics representative.

2.2 Locating the Instrument

The Ultrapure-100 must not be placed in an area susceptible to electronic noise and excessive mechanical vibration.

Locate the Ultrapure-100 within 1.5 meters (5 feet) of the external electrical power supply.

When installing the Ultrapure-100, verify that the display is visible to the user.

2.3 Standard Precautions

The following are standard precautions that must be considered during the installation procedures:

- Observe electrostatic discharge (ESD) precautions when handling the Ultrapure-100 to avoid damage to the unit.
- Attach all electrical cabling and fluid connections before applying power to the system. See [“Good Sampling Practices” on page 43](#) for notes on sample line connection and good practice.
- Visually inspect the system for the presence of any fluid leaks before applying power to the system.
- Always apply power to the counter after power is applied to all other equipment of the system.

CAUTION:

When the switch on the power supply is turned on, do NOT insert or remove the DC power plug into the back of the unit.

Note:

This equipment has been tested and found to comply with the limits for a Class A digital device, pursuant to Part 15 of the FCC rules. These limits are designed to provide reasonable protection against harmful interference when the equipment is operated in a commercial environment. This equipment generates, uses, and can radiate radio frequency energy and, if not installed and used in accordance with the instruction manual, may cause harmful interference to radio communications. Operation of this equipment in a residential area is likely to cause harmful interference, in which case the user will be required to correct the interference.

2.4 Device Familiarization

The Ultrapure-100's user interfaces are all located on the front panel of the instrument. These comprise the flow meter, the data display and the power and diagnostic indicators.

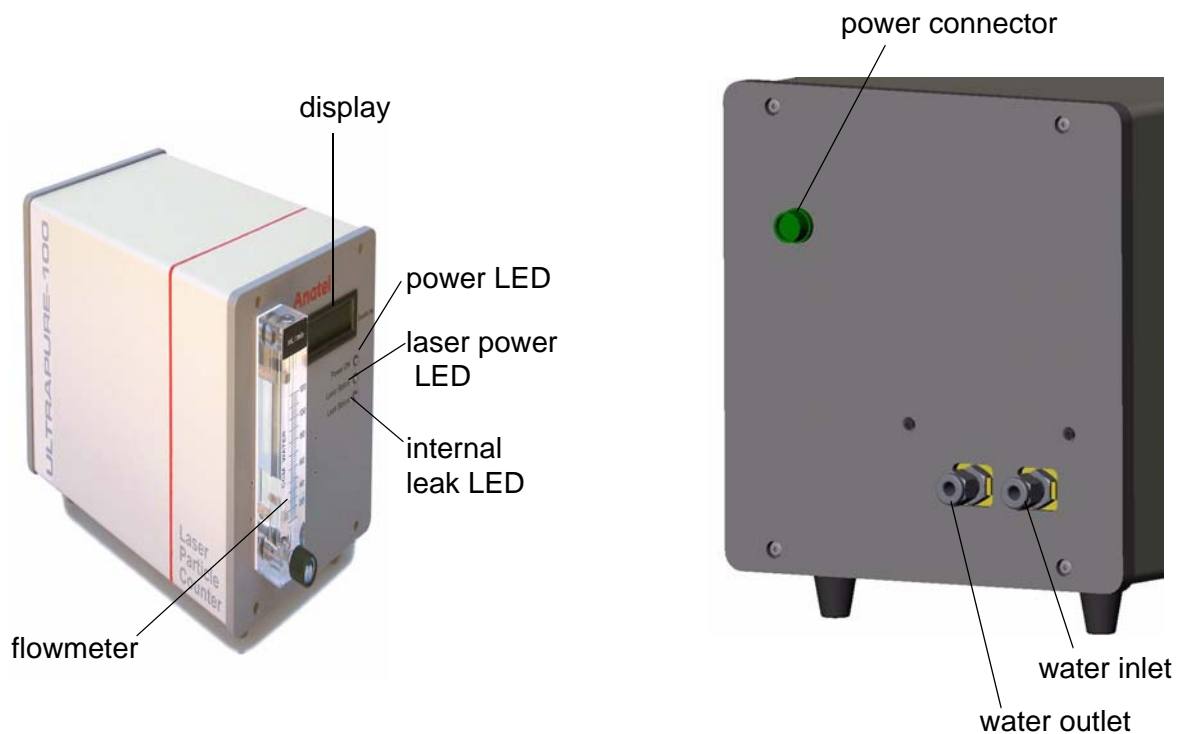

Fig 2-1 : Front and Rear Panel Layouts

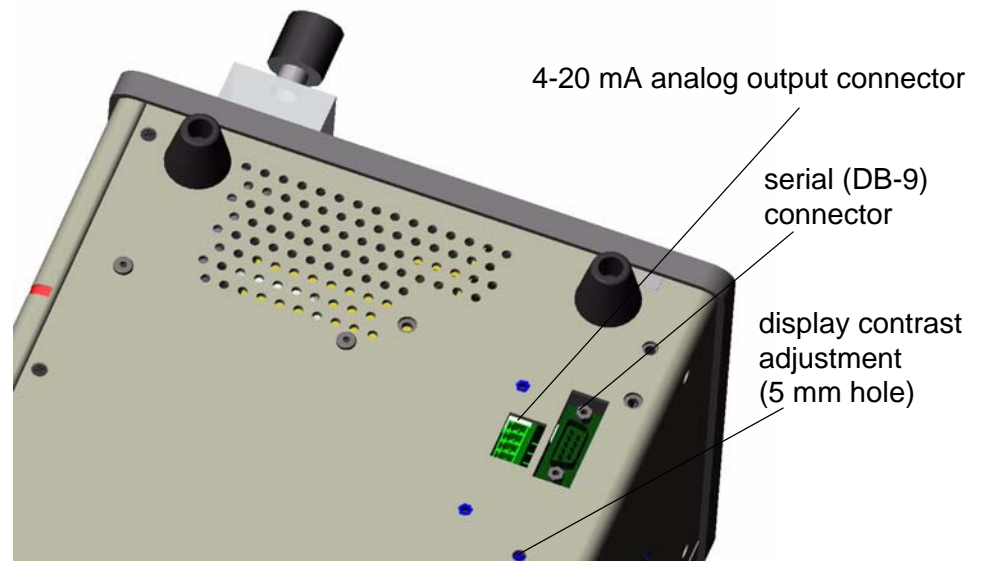

Fig 2-2 : Base Panel Layout (Base Cover Removed)

a) Front Panel Display

The counter features a two line by 24 character liquid crystal display that indicates the number of particle counts per mL of fluid. The display is located on the front panel (see [Figure 2-1](#)). A display contrast adjustment control is located on the underside of the unit, accessible via a small 5 mm hole (refer to [Figure 2-2](#)). The operator can adjust the contrast of the display by inserting a small flathead screwdriver into the hole, and adjusting the control potentiometer. Turning the potentiometer counterclockwise brightens the display; turning the adjustment control clockwise darkens the display.

b) Rear Panel

The connections on the rear panel are shown in [Figure 2-1](#). The connections are:

- DC electrical power
- Sample inlet
- Sample outlet

The fluid connections are ¼" Swagelok[®] fittings.

c) Base Panel Connections

The DC electrical power connector is supplied with +5 VDC and ±15 VDC via the connection from the external power supply unit supplied with the Ultrapure-100 product.

CAUTION:

ONLY OPERATE THE SYSTEM USING THE PROVIDED POWER SUPPLY.

Located on the base of the Ultrapure-100 are the 4-20mA analog connector(s) and the serial connector. These are found beneath the user-removable base cover, secured to the base by four large slotted thumbscrews.

The Ultrapure-100 uses a DB-9 connector for communication with a host computer or facility monitoring system, either RS-422 or RS-232.

The counter automatically sets the baud rate with the computer through the auto baud instruction described in [“Remote Control ASCII Commands” on page 27](#).

The maximum allowable cable lengths are:

- For the RS-232, 15.24 m (50 ft.)
- For the RS-422, 1219.2 m (4000 ft.)

3 Operating Instructions

The Ultrapure-100 Particle Counter is a digital, state-of-the-art, compact 2-channel (4-channel optional) particle counter that provides sensing, processing, and communications for monitoring liquid applications at point-of-use stations, as well as UPW monitoring applications.

The counter requires an external system to log particle count data. The count data are transferred to data logging (e.g. SCADA system) via 4-20 mA analog current signals or to a computer through RS-422 or RS-232 serial communication.

If the default instrument settings must be changed, use the Ultrapure-100 Setup Utility PC software described in [“Reconfiguring Analyzer via Utility Program” on page 18](#).

Note:

The Ultrapure-100 display AND the 4-20 mA analog output show particle counts normalized to counts per milliliter (mL). However, the serial communications connector transmits raw data, which must be appropriately scaled by the logging device as a function of the sample time. The Ultrapure-100 analyzes 1 mL for every 20 seconds of sample time. (For information on flow-through volume, refer to [“Particle Counter Technical Specifications” on page 39](#).) For example, if a sample time is set for 60 seconds, then the raw counts represent the total number of observed counts per 3 mL of processed fluid. The logging device should then divide the raw transmitted data by 3 to obtain counts per 1 mL. However, CountSpec™, Particle Vision® Online (PVO), and CIMScan® software packages automatically scale the data to counts per mL.

3.1 Controls and Indicators

The Ultrapure-100 has several indicators and controls accessible to the user.

a) Power Indicator

The power ON/OFF indicator is located on the front panel. When the counter is turned on, a green LED on the front panel lights to indicate counter power.

b) Laser Power Diagnostic

The laser power diagnostic indicator shows the operational state of the laser. The indicator is off during normal operation. When the indicator is illuminated RED, the laser power is below recommended levels, and the unit needs to be returned to the factory for service.

c) Internal Leak Status Indicator

The leak status indicator shows the presence of fluid within the enclosure. The indicator is off during normal operation. When the indicator is illuminated RED, the internal leak detector has sensed the presence of fluid within the system.

The system should be turned off, the fluid should be removed and the fluid source eliminated prior to reapplying power to the system.

d) Baseline Fail Message

The presence of a “BASELINE FAIL” message on the LCD display indicates that an excessive amount of stray light is being scattered in the flow cell. This is caused by one or more of the following conditions:

- The sample fluid is excessively dirty
- The cell is contaminated and needs to be cleaned
- A high level of bubbles exists in the sample

A baseline fail condition also drives the 4-20 mA current output signals high to 20 mA. Also, the letter “B” will be appended to the end of the serial data output string if Baseline Fail detect is enabled, refer to the command set shown in [Table 5.4 on page 28](#) or the Windows™ Utility program that supplied with the Ultrapure-100, described in [“Reconfiguring Analyzer via Utility Program ” on page 18](#).

e) Display Contrast Control

The Ultrapure-100 display has a contrast control located on the underside of the counter beneath a removable access panel (see [Figure 2-2 on page 11](#)). By inserting a small flathead screwdriver into the port, the user can adjust the display’s contrast.

3.2 Pre-operating Procedures

Remote monitoring of the counter requires that either the 4-20mA connector has been wired correctly to a data logging device (see [“Remote Data Logging” on page 23](#)) or a computer and compatible monitoring software is present in the system and that an ASCII or SECS-II communications protocol environment has been established (either RS-422 or RS-232). See [“Remote Control ASCII Commands” on page 27](#).

a) Connecting the 4-20 mA Analog Output

- 1) Remove the protective cable cover from the bottom of the unit.
- 2) Loosen the cable clamp screws on the cover (see [Figure 3-1](#)) and feed the output wires through the access holes in the cable clamp and the foam seal block.

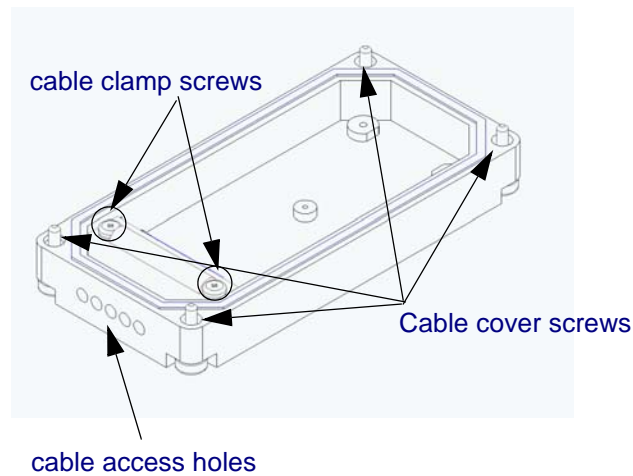

Fig 3-1 : Cable Cover

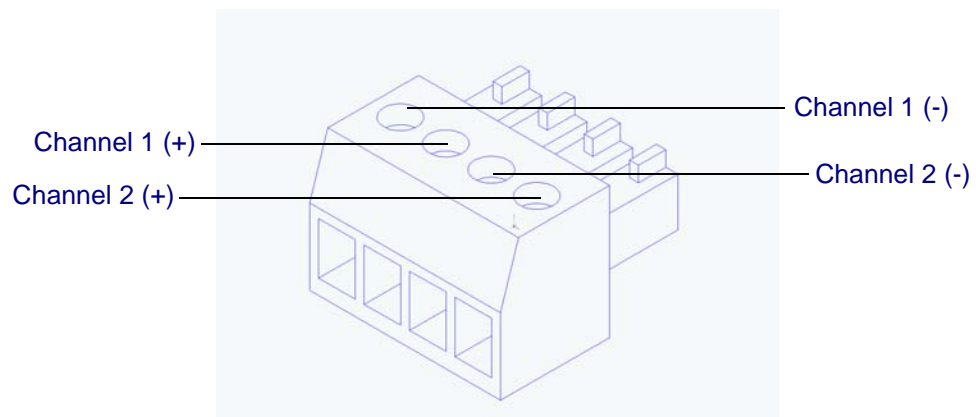

Fig 3-2 : 4-20 mA Connector Header

- 3) Connect the 4-20 mA output cables to the supplied header, as shown in [Figure 3-2](#). Insert the connector into the mating receptacle on the bottom of the unit.
- 4) Tighten the cable clamp screws and reinstall the cable cover.

b) Making Fluid Connections

- 1) Select appropriate sample points on the system to be monitored. Sample points should supply adequate pressure at the specified system flow rate.
- 2) Verify that the electrical power cord has been disconnected from the unit.

- 3) Remove the protective caps from the inlet and outlet fittings on the rear of the Ultrapure-100 and connect the ¼" sample tube with the 3-piece compression fitting components included in the ship kit.
- 4) Insert the fluid line from the supply into the inlet bulkhead fitting of the unit. Tighten the fitting nut securely to swage the compression ferrules onto the tube.
- 5) Insert the fluid line into the waste line into the outlet bulkhead fitting of the unit. Tighten the fitting nut securely to swage the compression ferrules onto the tube.
- 6) Pressurize the fluid inlet line and inspect for leaks at the newly made external fluid connections. Internal leaks will be detected by the internal leak detector.

c) Flowmeter Considerations

The flow system has been preset at the factory for 100 mL/min sensor flow rate, as displayed on the end panel flowmeter. The system has been designed to operate with system line pressures between 7 and 100 psi. After connecting the unit to the water system, adjust the sensor flow rate to 100 mL/min, if required, by adjusting the flowmeter needle valve.

The sensor flow rate will remain regulated at 100 mL/min \pm 10% when the water system line pressure remains between 30 and 100 psi.

3.3 Ultrapure-100 Analyzer Operation

CAUTION:

These steps must be followed in order to ensure proper operation of the Ultrapure-100 particle counter:

- 1) Ensure that all external connections are secure, including those for power, communications, and the sample inlet and outlet.
- 2) Plug the power supply DC output cord into the rear of the Ultrapure-100 and then connect the power supply AC power cord into a wall outlet. Turn the power supply switch to the on (1) position. The POWER indicator LED on the Ultrapure-100 front panel should now be on (green).
- 3) The Ultrapure-100 display and 4-20mA outputs will now update every 20 seconds (default).

Note:

If a computer control system is connected to the Ultrapure-100 serial port, the system is also controllable via the utility software. Be aware that the "BASELINE FAIL" error may display during the first sample period.

The display shows the particle count data as described in [Table 3-1](#), normalized to counts per mL, which are also transferred from the counter to the 4-20mA analog connector. Note that the data sent via the serial port are NOT normalized. The counter displays counts at the end of each run (default sample time is 20 seconds), even without active communications with a computer.

Table 3-1 : Format of Data Shown by the Ultrasure-100

	Data Format	Notes
DISPLAY	Normalized counts/mL	
4-20 mA	Normalized counts/mL	Refer to "Remote Data Logging" on page 23
RS-232/422	Raw data	Refer to "Writing an Ultrasure-100 Serial Driver" on page 31

Observe these guidelines to ensure accurate counts:

- Allow the Ultrasure-100 sensor to warm up for at least 30 minutes before collecting data.
- It is good practice to establish fluid flow prior to connecting electrical power. This will prevent the laser beam's heating effect from causing drying stains on the particle sensor cell component.
- When the sensor is not in use, or is being stored, verify that the flow cell is clean. Nonvolatile compounds can coat the flow cell windows, making cleaning very difficult. To completely empty and dry the system, connect the sample inlet to an N₂ source for 10 minutes. Do not overpressurize the system.
- Verify that the sample is at room temperature or warmer. Cold samples can cause condensation on the outside of the cell windows. Cold samples can also create air bubbles due to outgassing which will cause a false count.
- All sampled fluids **MUST** be compatible with the components used in the sample path. The Ultrasure-100 system is not warranted for use with chemicals incompatible with the materials in the fluid path of the sensor.

CAUTION:

Use of incompatible chemicals will void the unit warranty.

3.4 Data Output Parameters for 4-20 mA

The 4-20 mA analog output is per specifications shown in [Table 3-2](#).

Table 3-2 : 4-20 mA Analog Output Specification

Count Accuracy	$\pm 0.5\%$ Full Scale
Maximum Loop Resistance	500 Ω (including wiring & sense resistor)
Loop Current [mA] (Linear Mode)	$(\text{Counts} \times 16 / \text{FS}) + 4$ Where FS = Full Scale value. See Setup utility. Where i = Loop Current.
Counts pre mL (Linear Mode)	$(i - 4) / 16 \times \text{FS}$ Where FS = Full Scale value. See Setup utility.
Loop Current [mA] (Log Mode)	$4 \cdot [\log_{10}(\text{Counts} + 10)]$
Counts pre mL (Log Mode)	$10^{(i/4)} - 10$ Where i = Loop Current.

3.5 Reconfiguring Analyzer via Utility Program

The Utility program permits configuration changes to be made from a PC connected to the Ultrasure-100 via its RS-232 or RS-422 port.

In addition to set up functions, the program will also allow data to be collected from the Ultrasure-100 in real time so that the integrity of the Ultrasure-100 and its installation may be verified prior to running 4-20 mA communications cable.

a) Setup Utility program PC Operating System and Hardware Requirements

The Utility program requires:

- Microsoft™ Windows 2000, XP, 98SE, or NT 4.0 with Service Pack 6 operating system
- Intel® Pentium® 200 MHz or faster
- Minimum of 64 MB of RAM
- At least one serial port
- 20 megabytes of free hard drive space
- Microsoft .NET Framework version 1.1.

The installation program prompts to install .NET if it is not already installed on the computer. If selected, the installation program installs the .NET framework.

b) Setting the Ultrasure-100 Operational Parameters via Utility Program

Figure 3-3 shows the user-adjustable “Settings” screen, accessible from the “Settings” tab.

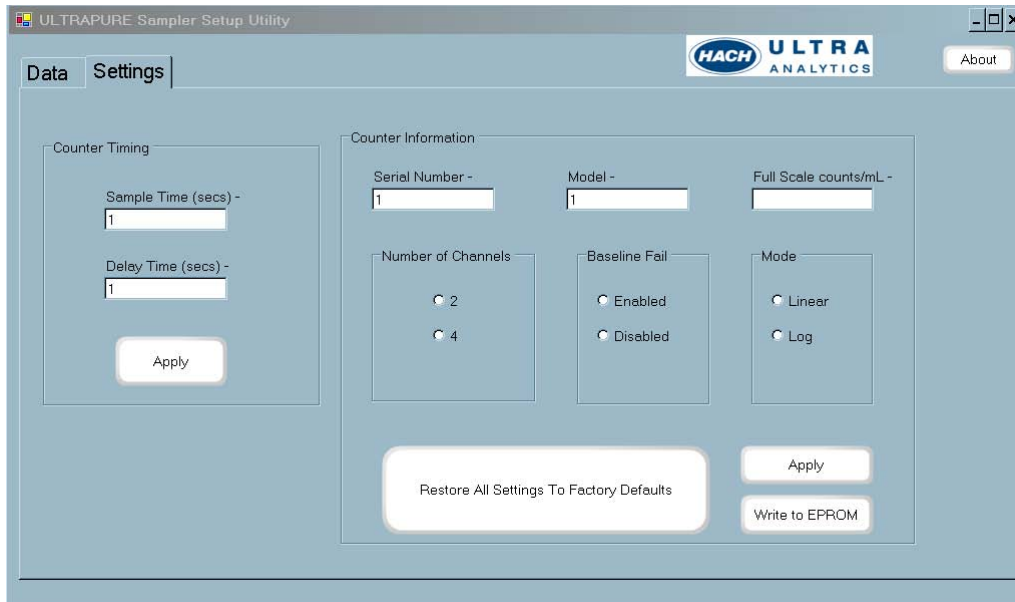

Fig 3-3 : Ultrasure-100 Setup Utility Program, Setting Screen

The “Settings” screen is not accessible unless an Ultrasure-100 is connected to a valid serial port. The Serial number and Model fields cannot be changed; however, modifiable functions are as follows:

Sample Time – Enter a sample time in seconds (1 to 99999).

Delay Time – Enter a delay time in seconds (1 to 99999).

Apply – This will program the counter with the configured settings.

Restore – Re-establishes factory defaults, which are:

- Sample Time = 60 seconds
- Delay time = 0 seconds
- Number of Channels = 2
- Baseline fail detect enabled.
- Analog output full scale = 1000
- Analog output mode = LINEAR

Write – To commit settings to nonvolatile EEPROM

Note:

Select Apply and then Write to have settings written to EEPROM.

c) Utility Program Acquisition, Display, and Storage

Figure 3-4 shows the Utility program's data handling function.

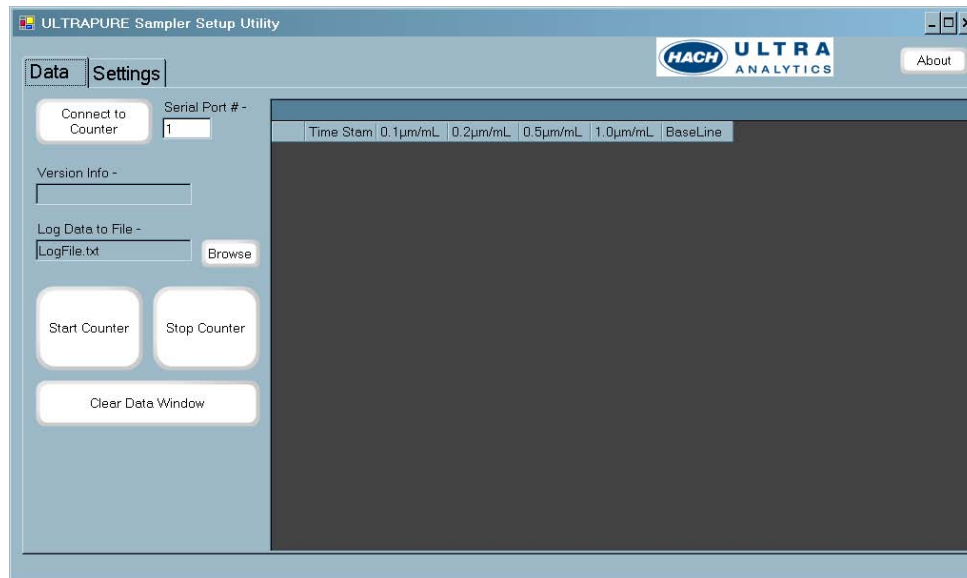

Fig 3-4 : Utility Program Data Screen

The functions available from this screen are as follows:

Serial Port – Establishes the serial port to be used for communications.

Connect to Counter – Initiates communications to the counter and obtains current Setup parameters:

Version Info – Displays the current version of the Ultrasure-100 firmware.

Browse – Allows the user to name/select a data file name.

Start Counter – Starts the Ultrasure-100 counting.

Stop Counter – Stops the Ultrasure-100 counting.

Display Area – Shows data in columns as they are obtained from the Ultrasure-100. The column headers will be labeled with the appropriate particle size (obtained from the “Settings” screen). There will be columns for date and time. A final column will show baseline status if enabled.

Log Data to File – The file where the count data will be logged. The “Browse” button can be used to select the location and filename for the log file.

All data display as counts per mL.

3.6 Operator Maintenance

The external surfaces of the unit may be cleaned. Always turn the power off before cleaning. Use a lightly moistened lint-free cloth or a vacuum cleaner to clean the external surfaces.

CAUTION:

Do not use solvents, which may damage the display and flow meter components.

a) Operator Troubleshooting

Operator troubleshooting is confined to verifying instrument connections and to noting the status of the diagnostics listed in [Table 3-3](#).

Table 3-3 : Troubleshooting Diagnostics

Baseline High	<ul style="list-style-type: none"> Indicated on the display as "BASELINE FAIL" See "Particle Counter Technical Specifications" on page 39
Internal Leak	Indicated by front panel LED
Laser Power	Indicated by front panel LED
Sensor Noise	<ul style="list-style-type: none"> Established by performing "no flow count test" See "Particle Counter Technical Specifications" on page 39

4 Remote Data Logging

The Ultrapure-100 Particle Counter 4-20 mA output provides 2-channels (4-channel optional, specified at time of ordering) of analog output for data acquisition. An external mating plug to the 4-20 mA connector is provided beneath the base cover of the unit. This plug allows the user to connect the Ultrapure-100 to data logging devices such as PLCs, SCADA systems, chart recorders, process voltmeters, etc. to the counter. The counter updates the analog output at the end of each counting period.

The 4-20 mA output connection is found under the removable base of the instrument and is located beside the COM connector. [Figure 4-1](#) illustrates the connector pin-outs.

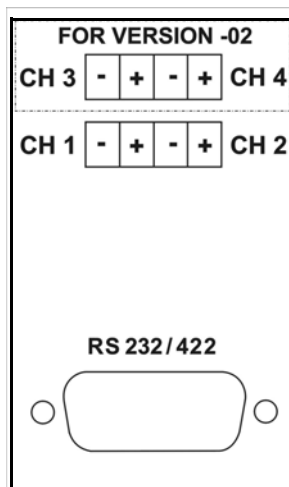

Fig 4-1 : Connector Pin-outs

Table 4-1 : 4-20 mA Specifications

Count Accuracy:	± 0.5% Full Scale
Maximum Loop Resistance	500 Ω (including wiring & sense resistor)

Use either the linear or logarithmic transform function to convert the loop current to particle counts. Logarithmic scaling is best; however, many data acquisition software systems can only handle linear transform functions.

Table 4-2 : Scaling Equations

Loop Current [mA] (LINEAR Mode)	$(\text{Counts} \times 16 / \text{FS}) + 4$ Where FS = Full Scale value. See "Reconfiguring Analyzer via Utility Program" on page 18. Where i = Loop Current.
Counts pre ml (LINEAR Mode)	$(i - 4) / 16 \times \text{FS}$ Where FS = Full Scale value. See "Reconfiguring Analyzer via Utility Program" on page 18.
Loop Current [mA] (LOG Mode)	$4 \cdot [\log_{10}(\text{Counts} + 10)]$
Counts pre ml (LOG Mode)	$10^{(i/4)} - 10$ Where i = Loop Current.

4.1 Data Table for Log Mode

[Table 4-3](#) indicates the particle counts associated with various 4-20 mA output currents when the output scaling is logarithmic.

Table 4-3 : Log Mode Data

Actual Counts per mL	mA	Volts (250 Ω load)	% F.S.
0	4.00	1.00	0.00%
1	4.17	1.04	1.03%
2	4.32	1.08	1.98%
10	5.20	1.30	7.53%
100	8.17	2.04	26.03%
1000	12.02	3.00	50.11%
10000	16.00	4.00	75.01%
75000	19.50	4.88	96.88%
Baseline High	20.00	5.00	ERROR

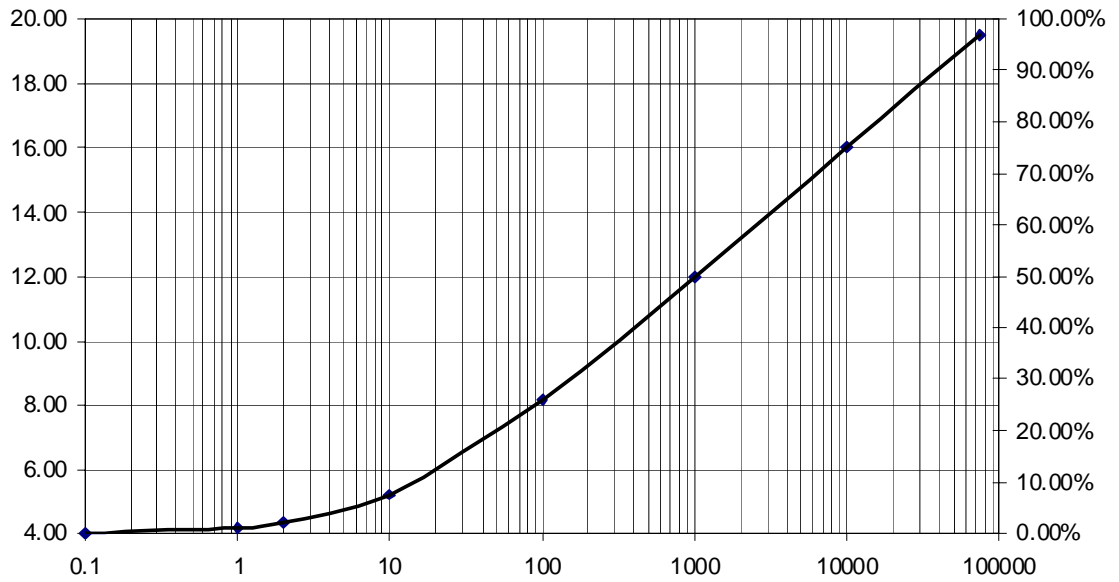

Fig 4-2 : 4-20 mA Response in Log mode

4.2 Data Table for Linear Mode

The following table indicates the particle counts associated with various 4-20 mA output currents when the output scaling is linear.

Note that in linear mode the full scale value may be selected. Table 4-4 is based upon the default full scale value of 100 counts per ml. Refer to the Setup utility software for altering these parameters.

Table 4-4 : Setup Utility Parameters

Actual Counts per mL	mA	Volts (250 Ω load)	% F.S.
0	4.00	1.00	0%
1	4.16	1.04	1%
2	4.32	1.08	2%
3	4.48	1.12	3%
4	4.64	1.16	4%
5	4.80	1.20	5%
6	4.96	1.24	6%
7	5.12	1.28	7%
8	5.28	1.32	8%
9	5.44	1.36	9%
10	5.60	1.40	10%

Table 4-4 : Setup Utility Parameters

Actual Counts per mL	mA	Volts (250 Ω load)	% F.S.
20	7.20	1.80	20%
30	8.80	2.20	30%
50	12.00	3.00	50%
80	16.80	4.20	80%
90	18.40	4.60	90%
Baseline Fail	20.00	5.00	100%

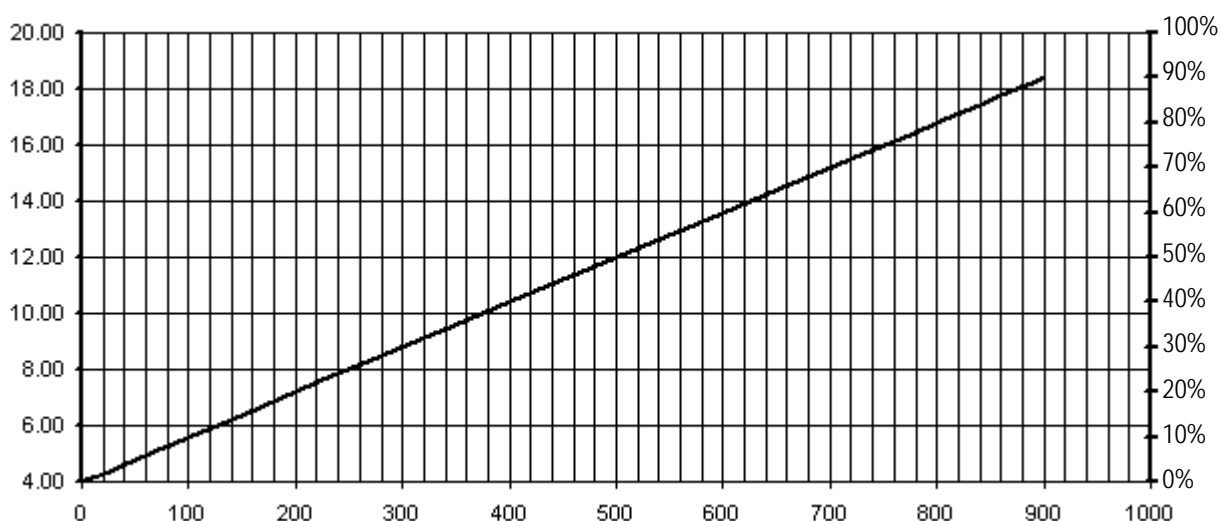

Fig 4-3 : 4-20 mA Response in Linear Mode

a) Baseline Errors

To detect a sensor fault status, it is recommended that an alarm threshold (in log mode) be set at 85,000 counts (19.7 mA).

A reading that exceeds this value represents a baseline error condition.

A baseline high condition can occur (20 mA) as the result of:

- A blockage of sensor flow cell.
- The sample liquid being extremely dirty, causing an over-concentration condition.
- A failure of the sensor laser. Refer to “[Laser Power Diagnostic](#)” on page 13.

When a baseline fail condition occurs, the analog output does not go high until the end of the current counting cycle. The output will return to normal at the end of any counting cycle during which no fault has occurred. Also, during high baseline conditions, the diagnostic BASELINE FAIL appears on the Ultrasure-100 display.

5 Remote Control ASCII Commands

The Ultrapure-100 can be controlled remotely by a host computer communicating with the counter through serial communications protocol (ASCII of SECS-II). The host computer may start or stop operations, set counter operating parameters, and query for parameter values. The counter provides the host computer with numerical count data either automatically (“Data Logging” mode) or in response to a query from the host computer (“Polled” mode). The nonvolatile section of counter memory retains the counter parameters when the counter power is off.

5.1 Communications Protocol

The counter automatically matches the baud rate of the host computer; this feature is described in the “[Autobaud Operation](#)” on page 27. The 7-bit ASCII character set is used, with the counter ignoring the 8th (parity) bit on communications from the host. On communications to the host, the parity bit is always set to zero. The recommended serial port configuration is 9600 baud, no parity, 8 bits, 1 stop bit.

Incoming characters are not immediately echoed to the host. The counter must receive the complete command before it issues a response. When using a terminal emulation program on the host computer, the operator should set the emulator parameters to: Half Duplex, CR->CR+LF on Input. The counter itself does not support flow control. The host must *not* transmit information that overlaps with responses from the counter.

5.2 Data Integrity

For critical applications, data integrity checking can be supported by the host software. Every host computer command issued elicits a counter response that can be checked for validity. In addition, a message-based checksum is appended to the reported count data. If a sensor fault condition such as a “BASELINE FAIL” error occurs, the sensor fault is reported. The description of the **P** command below contains further details on checksum monitoring.

5.3 Autobaud Operation

The **A** command is used by the autobaud algorithm to determine the communications speed. The Ultrapure-100 supports four different baud rates: 1200, 2400, 4800, and 9600 baud. When the counter is turned on, the counter expects to receive an **A** command that determines the baud rate. The counter responds with **!A**. All Hach Ultra Analytics software automatically send the **A** command to the counter. If the counter detects four consecutive communications errors, for example, framing errors or overruns, the counter will revert to autobaud mode and attempt to initialize the baud rate again.

The following host algorithm will allow communication with a Ultrapure-100 regardless of the initial state of the counter:

- 1) Send <CR> and ignore any response.
- 2) Send **A** (without <CR>).
- 3) Check for response from the counter.
- 4) If no response, repeat [step 2](#) and [step 3](#) up to eight times.

- 5) If the counter has not responded after eight tries, a fault such as a power or cable fault has occurred.

Verify the connection and continuity of system cables and repeat this procedure. Contact Technical Support for further assistance if communications cannot be established.

5.4 Command Set

In [Table 5-1](#), *nnn* represents a whole number value that may have from one to ten digits; *xx* represents a two character string. Every command except the **A** command must be followed by a carriage return <CR>. Every counter response begins with an exclamation point and is terminated with <CR>.

Table 5-1 : Command Set

Command	Response	Function/Notes
A	!A	“Are you there?” used for autobaud detection.
S	!S	Start counting; Data Logging mode enabled. Note: Count data will be immediately reported at the end of each run using the format described under the P command.
S-	!S-	Start counting; Data Logging mode disabled. Note: Count data will not be reported unless polled with the P or Q commands.
H	!H	Halt counting. Note: Immediately interrupts the count accumulation that was in progress. Counts accumulated during the interrupted cycle are available using the P command, but the Q command will return !ND (no data).
Tnnn	!Tnnn	Set the sample time to nnn seconds. Note: nnn=0 sets the counter to “manual” mode; counting will continue until the next H command.
T	!Tnnn	Report the current sample time setting in seconds.
Dnnn	!Dnnn	Set delay time between samples to nnn seconds.
D	!Dnnn	Report the current delay time setting in seconds.
I1	!I1	Turn on ALARM indicator light.
I0	!I0	Turn off ALARM indicator light. (0 is a zero)
K	!K	“Keep”; store the parameter values in nonvolatile ?K SAVE ERR memory. If parameters are not successfully saved, ?K SAVE ERR response occurs. Note: Nonvolatile memory is rated for 10,000 write cycles.
V	!Vn.n,UP-100,nnn	Read back counter identification (n.n is the firm-ware version number, UP-100 is the counter model number, and nnn is the counter serial number).

Table 5-1 : Command Set

Command	Response	Function/Notes
P	!nnn,nnn[,nnn,nnn],xx[,BL]	Read back count data from the most recently completed run. The first two numbers are the cumulative counts for Channel 1 (most sensitive channel) and Channel 2. Channel 3 and Channel 4 data follow. A two character hexadecimal checksum xx follows the count data. The checksum is computed by summing the 7-bit ASCII character values from the beginning of the line, including the ! character and the , preceding the checksum. The final ,BL only appears if a Baseline Fail condition has occurred.
Q	!nnn,nnn[,nnn,nnn],xx[,BL]	Query for count data (in Polled Mode). If new !ND count data are available, the count data are reported in same format described for the P function. If no sample period has been completed since data were last read, !ND "No Data" response is given.
P+	!P+	Turn on Data Logging mode, the automatic count report at the end of each sample. Unlike the S command, this does not initiate counting if the counter is halted.
P-	!P-	Turn off Data Logging mode. Unlike the S command, this does not initiate counting if the counter is halted.
MP	!nnn,nnn[,nnn,nnn],xx[,BL]	Returns the data stored in the Peak memory; see "Peak Hold" on page 29
MR	!MR	Reset Peak memory. Counter response to any unrecognized command.

5.5 Peak Hold

The Peak Hold feature addresses the problem of monitoring a process when an interruption occurs in the data-logging system communications.

When monitoring a filtration process, the best method for achieving satisfactory results involves using a computerized on-line data-logging system. When such a system is in use, trends, daily variations and other patterns can be discovered quickly. In addition, the data will provide almost up-to-the-minute information on a filtration process.

However, if an interruption occurs in the data-logging system communications (such as a power failure to a multiplexer), the operator must determine whether the process maintained integrity in the time interval during which the communications were interrupted. The Peak Hold feature provides the operator with a tool for determining this performance level.

In contamination monitoring situations, the operator is concerned about high particle concentration situations. Low particle concentrations generally represent a satisfactory state. Peak Hold occupies an area of memory that retains the maximum particle count data recorded for each size threshold since the last memory reset. The Ultrapure-100 stores this information

until the counter receives an explicit **MR** (Peak Memory Reset) from the data-logging host computer. Note: memory is reset upon power up.

If the communications were interrupted, the counter would continue to monitor particle counts and retain the maximum particle count data indefinitely. Once communications resume, the operator can immediately check the peak memory with the **MP** command. The numbers in the peak memory will verify the maximum particle levels from the entire period of the interruption, enabling the operator to determine instantly whether the filtration process maintained satisfactory function.

The Peak Hold feature does not interfere with standard display of information in any way.

6 Writing an Ultrasure-100 Serial Driver

This section is provided as an example only of one possible implementation of the Ultrasure-100 serial command set. Refer to the command set shown in [Table 5-1 on page 28](#) for more information.

6.1 Initialization Sequence (After Power-up of the Ultrasure-100)

Table 6-1 : Initialization Sequence (After Power-up of the Ultrasure-100)

Send	Receive
A	!A [Note: If !A is not received then repeat]
D0	!D0
T0	!T0
P-	!P-

Table 6-2 : Running Sequence

Send	Receive	Note
S	!S	Start command; this initiates counting. Counting continues until the H command is sent, so wait for the desired sample time to pass before sending the H command.
H	!H	Halt command; this terminates counting.
P	!NNN,NNN,NNN,NNN,CS,BL	Pool the data; this is the data output shown in Figure 6-1 .
To take another sample, repeat this sequence.		

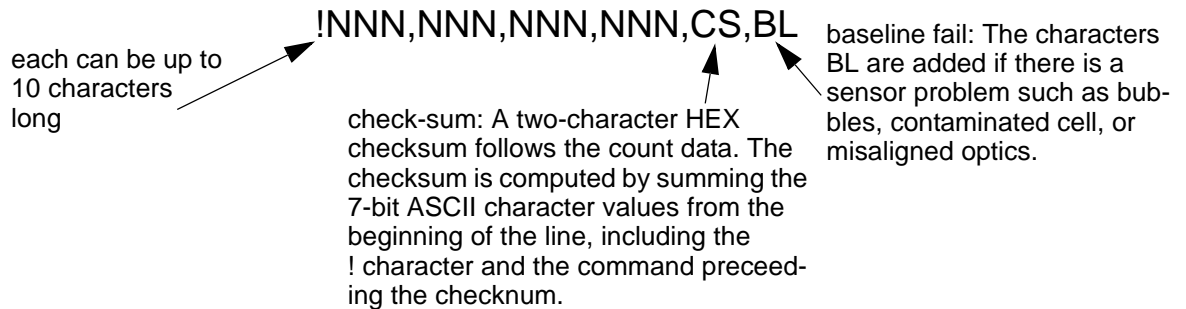

Fig 6-1 : Data Output Format

7 Configuring CountSpec Software for Use with Ultrasure-100

This procedure assumes that CountSpec software has been loaded on to a suitable computer (see CountSpec manual) and that the computer has been connected to the Ultrasure-100 serial port.

Table 7-1 : Configuring CountSpec Software for a Job

Step	Action	Sub-actions
1)	Select a Password.	a) Start CountSpec software. Select Register if the program has not been registered. b) Select OK . c) Select Security from the menu bar. Choose login. d) Enter name as countspec and password and countspec. Use lower case characters. e) Select OK .
2)	Configure the sub-parameters for the device.	a) From CountSpec, select Configure . b) Select Setup . c) Choose Device . d) In the name box type Ultrasure-100. Select Enter . e) From the device type pull-down choose 2000 and type the Ultrasure-100 serial number in the box below. f) From the sampler pull-down, choose none and leave the serial number box blank. g) From the sensor pull-down, choose MC100 and type the Ultrasure-100 serial number in the box below. h) Enter the sensor calibration date and the due date. i) Enter 100 in the flow rate box. j) Enter 3 in the View Factor box. k) Enter the four particle sizes of interest. 0.1, 0.2, 0.5, 1.0. (This assumes that the Ultrasure-100 counter is using the factory default channel thresholds.) l) Select File . m) Choose Save . n) Select OK . o) Select File . p) Choose Exit .
3)	Configure the sub-parameters for sampling.	a) Select Setup . b) Choose Sampling . c) From the Name pull-down choose On-line . d) Enter Delay Time = 0. e) Enter Sample time in seconds as desired (typically = 60). f) Enter number of samples as desired (example: 240 which = 4 x 60min = 4 hours). g) Enter Time between sets = 0. h) Enter number of samples to ignore = 0. i) From the sample method pull-down menu, select Sets . j) Enter sample runs = 1. k) Select File . l) Choose Save . m) Select OK .

Table 7-1 : Configuring CountSpec Software for a Job

Step	Action	Sub-actions
4)	Set up the file information for particle counting.	<ul style="list-style-type: none"> a) Select File. b) Select Setup. c) Choose Batch Entry d) Type DI Tests in the Name box. e) Type the operator name in field 1. f) Type the sample location in field 2. g) Select File. h) Choose Save. i) Select OK. j) Select File. k) Select Exit.
5)	Configure the job.	<ul style="list-style-type: none"> a) In Job Name box, enter <Job Name>. b) From Device pull-down menu, select Ultrapure-100. c) From Sample Method pull-down menu, select ON-LINE. d) From Alarms pull-down menu, choose —. e) From Data Entry pull-down menu, choose DI TEST. f) From User Prompts pull-down menu, choose —. Prompts are not required. g) In Access Level box, enter 0. h) Select File. i) Choose Save. j) Select OK. k) Select File. l) Select Exit.

Note that job <Job Name> is now available on the main CountSpec screen. Double clicking on the job name will start the configured sampling exercise running.

Appendix A: Service Procedures

A.1 Return Procedures

The Ultrapure-100 Particle Counter has a six-month calibration cycle. The Ultrapure-100 must be returned to an authorized service center for re-calibration after six months of the date of calibration, listed on the sticker on the back of the Ultrapure-100.

To return the Ultrapure-100 Particle Counter for repair or calibration, first obtain a returned material authorization number (RA#). The RA# number is necessary for any instrument that requires repair or calibration by an authorized service center. Include the RA# number on the shipping label when the instrument is returned.

While the RA# process is described in this section, for the most up-to-date RA# process information, including copies of all required forms, call Hach Ultra Analytics at 800.866.8854 or +1 541.472.6500.

To return an instrument for credit, please contact the local sales representative.



WARNING

The following actions must be performed when returning any unit for any reason to prevent personal injury and/or damage to the unit.

- When the sensor is not in use, or is being stored, verify that the flow cell is clean. Nonvolatile compounds can coat the flow cell windows, making cleaning very difficult.
- Before shipping, completely empty and dry the system, connect the sample inlet to an N₂ source for 10 minutes. Do not overpressurize the system.

a) United States RA# Process

- 1) Properly drain and/or decontaminate the unit prior to shipment. If a contaminated unit is received, Hach Ultra Analytics reserves the right to have the unit removed and destroyed by a hazardous materials disposal team at the shipper's expense.
- 2) Obtain a Return Authorization/Purchase Order Form by calling 800.866.8854. This form must be completed to obtain a Return Authorization Number (RA#) from Hach Ultra Analytics.
- 3) Complete the Return Authorization/Purchase Order Form, making sure every line is completed. Incomplete forms will not be given an RA#.
 - Main Contact: Full name of contact person; include phone/fax numbers.
 - Billing and Shipping Information: Include addresses, phone/fax numbers, and contact person.
 - Equipment Information: Include model number(s), serial number(s), and the reason for sending the equipment in (i.e., calibration and repair). Provide a detailed description of what is wrong with the unit.
 - Call Customer Service at 800.866.8854 and ask the Service Administrator for a NOT TO EXCEED monetary value for the RA/PO Form by giving the Administrator the model number(s) of the instrument and the reason for the return.

- Method of Payment: Mark the appropriate box on the bottom of the form (for credit card payment, please provide credit card information including the signature of the card holder).
 - If "As Received Data" is required, please check the appropriate box.
 - Provide taxable information.
 - If a return shipping method other than Federal Express 3-Day, please cross out this ship method, and provide the account number and ship method.
- 4) Once the form is complete, fax it to 541-479-3057. Within 24 hours a Return Authorization Number (RA#) is assigned.

Note:

If an RA# is needed immediately, please call 800.866.8854 after faxing it and the Service Administrator will supply one over the phone.

- 5) The RA# must be marked on the outside of the box before shipping any unit for repair or calibration. *Boxes received with no RA# marked on them will be returned.*
- 6) Additionally, customers returning units that use hazardous chemicals must review and complete the Hazardous Chemicals Information Form, available by calling 800.866.8854.
- 7) If applicable, after receiving the RA#, apply the Chemical Handling (CH) label to the outside of the shipping container: This label is available by calling 800.866.8854.

b) International RA# Process

- 1) Properly drain and/or decontaminate the unit prior to shipment. If a contaminated unit is received, Hach Ultra Analytics reserves the right to have the unit removed and destroyed by a hazardous materials disposal team at the shipper's expense.
- 2) Obtain a Return Authorization/Purchase Order Form by calling +1 541.472.6500. This form must be completed to obtain a Return Authorization Number (RA#) from Hach Ultra Analytics.
- 3) Complete the Return Authorization/Purchase Order Form, making sure every line is completed. Incomplete forms will not be given an RA#. This information must be provided:
- 4) Ship the unit to: Hach Ultra Analytics, 481 California Avenue, Grants Pass, OR 97526 USA
 - Consignee: Hach Ultra Analytics, 481 California Ave., Grants Pass, Oregon 97526 USA
 - Notify: Expeditors International 12302 North East Marx, Portland, Oregon 97230 Tel: 503.254.3707
 - Airport of Destination: Portland Airport, Oregon, USA
 - Please make sure that the commercial invoice clearly says that units are *Made in USA by Hach Ultra Analytics* and are being returned for repair or replacement. *Customs will hold shipment if no invoice is included.*
 - Freight charges: If the returned items are not covered under warranty, the customer is responsible for freight charges. If the item is covered under warranty, the customer will pay freight for returning the item to Hach Ultra Analytics. Hach Ultra Analytics will pay the freight to ship the replaced or repaired item covered under warranty. Hach

Ultra Analytics will return the repaired unit by the same method it was shipped to Hach Ultra Analytics.

- Import Charges: When airfreight is used to return items, Hach Ultra Analytics' broker charges an average of \$100.00 to \$150.00 to clear and deliver the shipment. Hach Ultra Analytics will bill the customer for these import charges. To avoid these charges, ship via a courier service such as Federal Express or UPS, who deliver directly to Hach Ultra Analytics, bypassing the customs broker.
 - Customs Value for Repair or Replaced Items: Please provide the "Declared value for customs" when completing the RA form. This is the value declared on the invoice. If not specified, the full repair value will be declared as customs value. Hach Ultra Analytics assumes no responsibility for damage to the product during shipment/transit. Please note that in case of transit damage, the amount claimable from insurance will be limited to the declared value.
- 5) The RA# must be marked on the outside of the box before shipping any unit for repair or calibration. *Boxes received with no RA# marked on them will be returned.*
 - 6) Additionally, customers returning units that use hazardous chemicals must review and complete the Hazardous Chemicals Information Form, available by calling +1 541.472.6500.
 - 7) If applicable, after receiving the RA#, apply the Chemical Handling (CH) label to the outside of the shipping container: This label is available by calling +1 541.472.6500.
 - 8) If the actual repair cost exceeds the approved cost, then an estimate will be provided. Revise the original approval / purchase order for the new amount within 30 days. If a revised order is not received within 30 days, the unit will be returned and Hach Ultra Analytics will charge a \$150.00 USD evaluation fee.

A.2 Technical Support Information

Technical Support Engineers are available to provide high quality advice and recommendations for applications, product operation, measurement specifications, hardware and software, factory and customer site training.

Please provide name, company, phone, fax, model number, serial number and comment or question.

Call +1 (541) 472-6500

Toll Free (800) 866-8854 (US/CA)

Fax +1 (541) 474-7414

6:00 AM to 5:00 PM Pacific Time

Monday through Friday

Email: TechSupportGP@hachultra.com

Appendix B: Particle Counter Technical Specifications

The particle sensor used in the Ultrapure-100 design (referred to as “the sensor” in this manual) is used for particle contamination monitoring of high purity samples such as ultrapure water loops.

The sensor optical system detects light scattered from particles, providing sensitivity as low as 0.10 μm . Each particle passing through the sensor scatters light, generating an analog electronic pulse at a photodetector; this signal is amplified and conditioned by the sensor circuitry. The analog pulse output of the sensor is processed by the Ultrapure-100 counting electronics, which determine the number of particles and the particle size in micrometers.

Sensitivity range	0.1 to 5.0 μm @ 100 mL/min
Concentration Limit	100,000 particles/mL (10% optical coincidence)
Flow Rate	100 mL/min
View Volume (% of flow sampled)	3% @ 150 mW
Light Source	150 mW (Typical) Near IR (837 nm) Laser Diode
Collection Optics	90° Light Scatter (0.1 μm to 0.4 μm) Near Forward Scatter (0.4 μm to 5.0 μm)
Maximum Operating Pressure	150 psi (1034 kPa)
Wetted materials	<ul style="list-style-type: none"> • Kel-F® or PCTFE • Quartz
Seals	Kal-Rez®
Sensor Fluid Connections (not Ultrapure-100 external fluid connections)	<ul style="list-style-type: none"> • 0.25 in (6.36 mm) Flare-Tek™ fittings • Teflon® tubing • 316L stainless steel

B.1 Laser Diode Characteristics

The particle sensor contained in Ultrapure-100 is certified to conform to the applicable requirements of US 21 CFR 1040.10 and 1040.11 (Radiation Control for Health and Safety Act of 1968, 42 U.S.C. 263f).

The sensor is designated by the Bureau of Radiological Health as a Class 1 product. As such, it will expose the operator to negligible levels of laser radiation during normal operation.



WARNING

Removal of the cover during operation may result in hazardous radiation exposure.

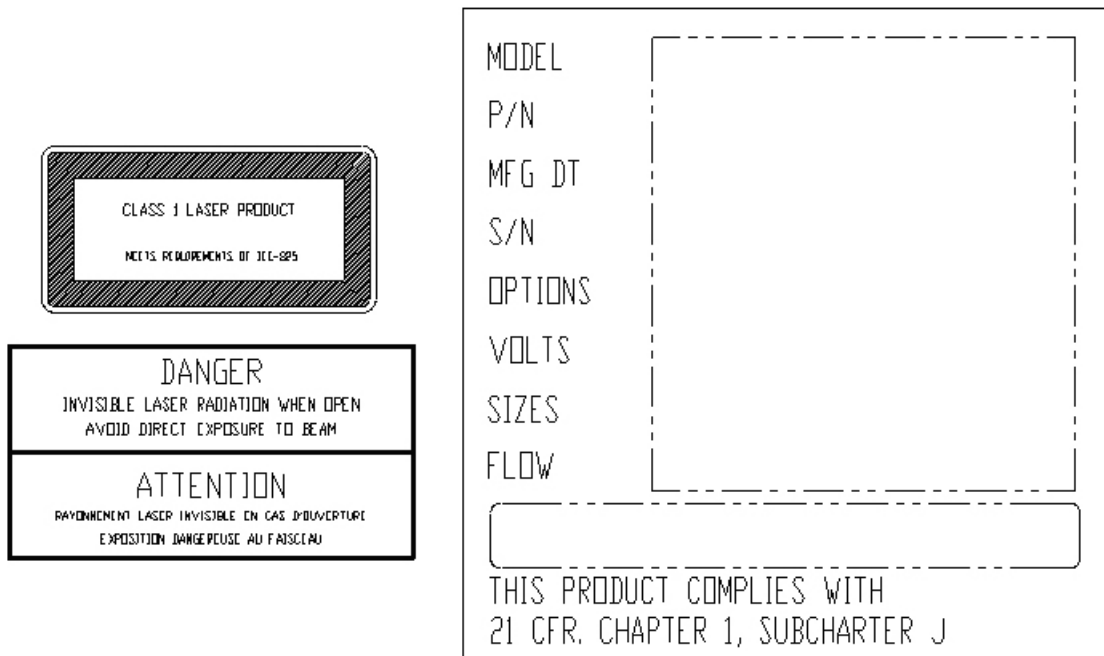

Fig B-1 : Safety Warning Labels

CAUTION:

Removal of the particle sensor covers by non-qualified personnel may destroy the laser diode and will void the warranty. The sensor contains no operator-serviceable assemblies. The use of control or adjustments of performance procedures other than those specified in this manual may result in exposure to hazardous radiation.

a) Sensor Theory of Operation

The sensor consists of particle sensing and detection elements, a power supply, and electronic elements.

The Ultrapure-100's sensor uses 90° light scattering to detect particles as small as 0.10 μm . The sample passes through the flow cell, where a laser beam passes through a window and the sample. When no particles are present, all the light passes through the flow cell and no light reaches the light-scatter photodiode.

The presence of particles scatters the laser light. The light-scatter photodiode collects this light and produces an electrical pulse. The pulse amplitude is proportional to the light intensity detected, which in turn is related to the particle size.

The sensor electronics amplifies the photodiode pulses to the signal strength expected by the counter. The counter identifies the quantity and height of the pulses.

The sensor has no operator controls or indicators and depends upon external devices such as the sampler and counter for its operational controls and indicators.

The counter identifies the quantity and height of the pulses by sorting the pulses into bins with predefined pulse amplitude ranges. The counter displays the sample data, and when controlled by a host computer, transfers this information to the host computer through serial communications.

b) Sensor Maintenance Procedures (Qualified Personnel)



WARNING

This section includes cleaning and maintenance procedures for the Ultrapure-100 particle sensor. Failure to follow these procedures, or attempts by unqualified personnel to perform these maintenance procedures may result in voiding the warranty. If in doubt, call a factory authorized service representative.

Safety Precautions and Warnings

CAUTION:

The laser diode in this device is extremely sensitive to static charges and out-of-tolerance voltage variations. Observe standard electrostatic discharge (ESD) safety procedures when servicing laser diodes. NEVER connect or disconnect the internal sensor cable from the Ultrapure-100 main PCB when the counter is on.

- Never make or break electrical connections when equipment is powered on.
- The sensor uses a laser diode. No access to this diode is required for operation or operator maintenance. There are no user-serviceable parts inside. Refer all servicing to qualified service personnel.
- Removal of the sensor covers at any time by non-qualified personnel may destroy the laser diode and void any warranty.
- This sensor contains no operator serviceable assemblies. The use of controls or adjustments or performance of procedures other than those specified herein may result in hazardous radiation exposure.

c) Sensor Cell Cleaning

Cleaning the sensor cell is rarely necessary and prior to conducting the following procedures it is highly advisable to verify that cleaning is in fact required. Unnecessary cleaning should be avoided, as a small risk of damaging the cell is always present. The best way to verify cell condition is to perform the No-Flow test described below.

d) Performing the No-Flow Test

Perform a No-Flow Test to determine if the flow cell requires cleaning.

- 1) To perform a No-Flow test, ensure that the MicroCount sensor is connected to a water system and a particle counter.
- 2) With water flowing through the sensor, observe a series of samples. Observe the count number displayed by the particle counter.
- 3) Turn off the flow of water through the sensor. Wait for a number of samples, observing the results. The counts for the each run should be zero (0).

- 4) If the particle counter displays any counts, clean the flow cell using the Floss Cleaning procedure described. After cleaning the flow cell, repeat the No-Flow Test to determine if the cell is cleaned.
- 5) If it is established that the sensor cell must be cleaned, refer to [“Floss Cleaning the Flow Cell”](#) to clean the cell.

e) Floss Cleaning the Flow Cell

CAUTION:

Only perform floss-cleaning after a No-Flow test shows cleaning is needed.

To clean the flow cell, use the floss (part number 660-850-0001) supplied in the ship kit. Additional supplies can be obtained from an authorized Anatel distributor.

CAUTION:

Do not use any other type of floss or the Ultrapure-100 may be damaged.

- 1) Turn off the power to the particle sensor, and remove the power cord.
- 2) Remove the inlet sample tube from the Ultrapure-100. Connect the Ultrapure-100 sample inlet to an N₂ or CDA gas source to coarsely drain the system.
- 3) Remove the side panel of the Ultrapure-100 to reveal the particle sensor.
- 4) Loosen both the top and bottom Flare-Tek nuts on the sensor fittings and remove the tubing from the top and bottom. Use paper wipes to catch any fluid drips.
- 5) Saturate the thick central portion of the cleaning floss (part number 660-850-0001) with water. (A solution of Micro™ can also be used).
- 6) Insert the non-waxed end of the floss into the top fitting and feed it through until the end of the floss can be seen emerging from the lower fitting.
- 7) Gently pull the floss through the sensor until the thick center section of the floss is in the flow cell. By holding the floss at both ends pull the floss back and forth through the cell 8 to 10 times.
- 8) Remove the floss from the sensor in the same direction it was inserted. DO NOT pull the waxed end through the cell. Reconnect the tubing to the top and bottom fittings with the Flare-Tek nut. Do not over tighten. Replace the side panel of the Ultrapure-100.
- 9) Reconnect the sample counter. Repeat the No-Flow Test described in [“Performing the No-Flow Test” on page 41](#) to determine if the cleaning procedure was successful.

Appendix C: Good Sampling Practices

Sources of bubbles and residual contamination can cause spurious results in liquid particle counting systems. The following is a list of conditions that if in existence up stream of the particle counting system can cause problems.

- Sudden changes in flow direction (multi-port fittings)
- Restrictions to flow (regulators, needle valves)
- Dead volumes (flow-meters)
- Direction of flow through sensor
- Stationary flow in dead-leg

C.1 Using Tee Pieces

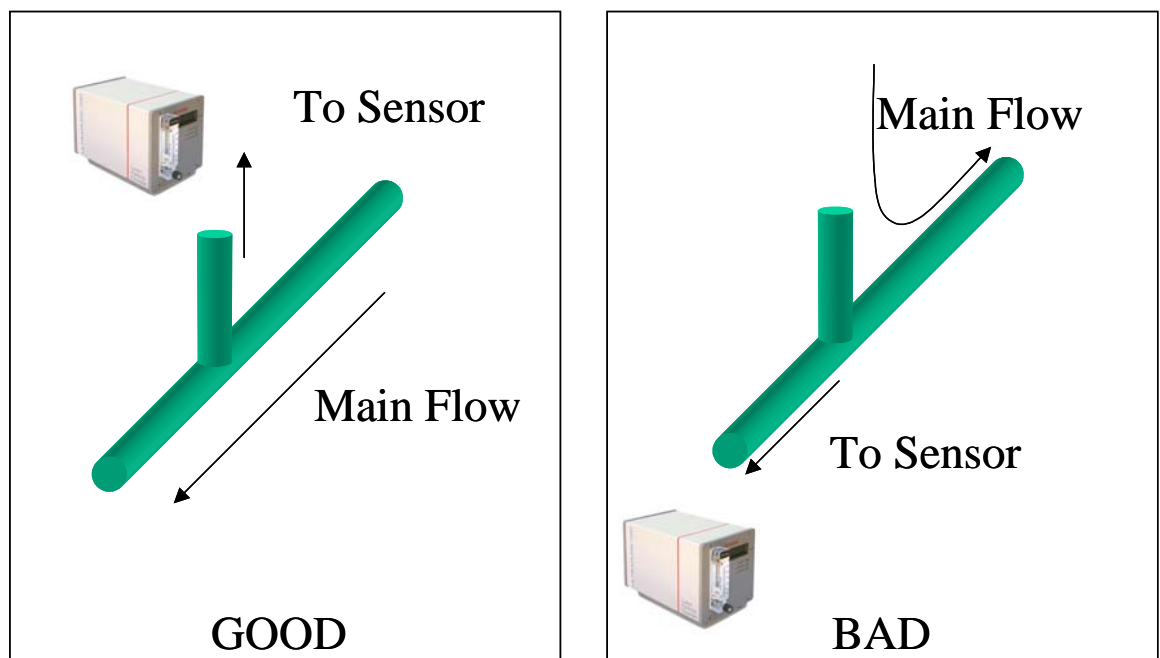

Fig C-1 : Examples of Good and Bad Tee Piece Placement

C.2 Using Multiport Valves

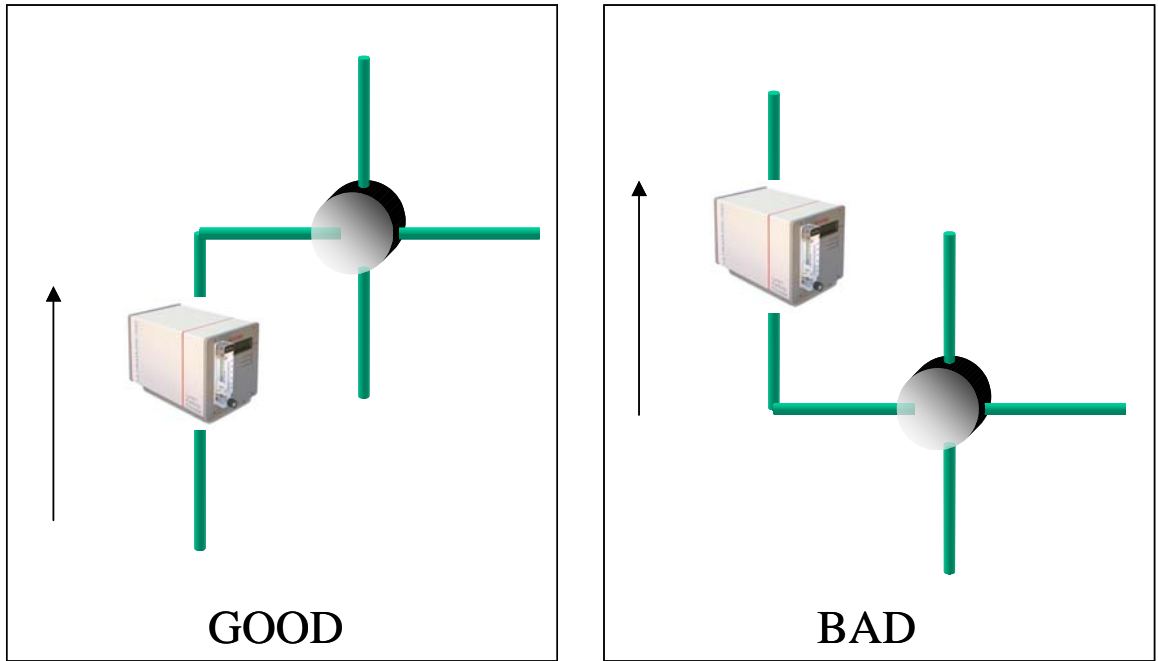

Fig C-2 : Examples of Good and Bad Multiport Valve Placement

C.3 Using Regulators

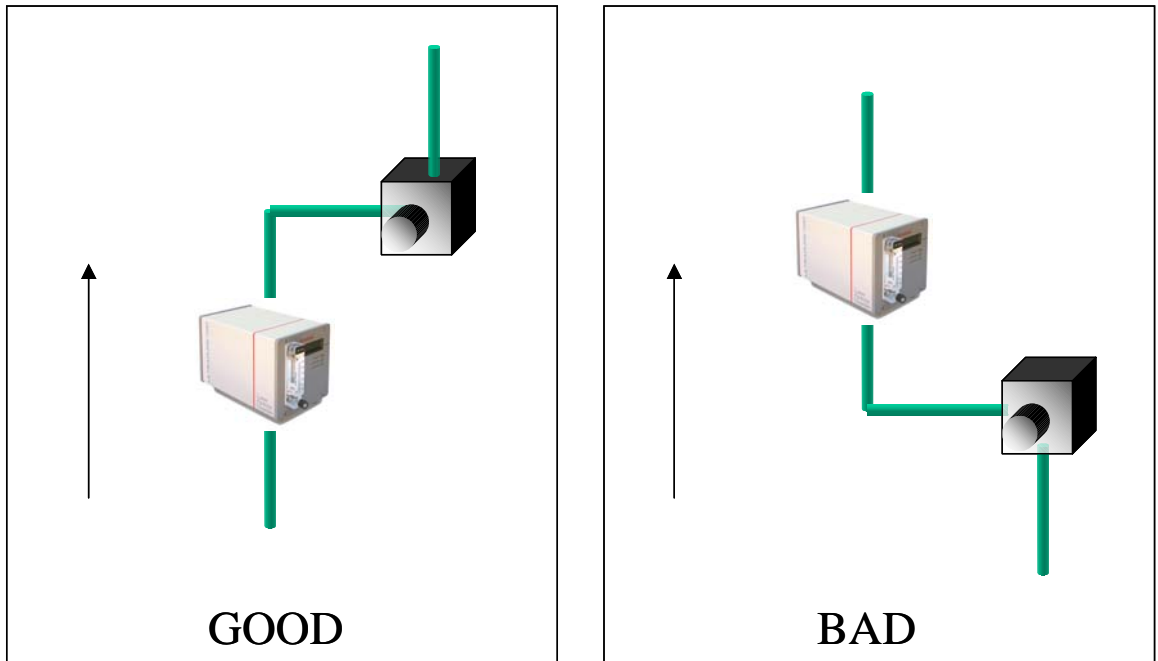

Fig C-3 : Examples of Good and Bad Regulator Placement

KSS - December 2003 - Edition 1

C.4 Dead-legs

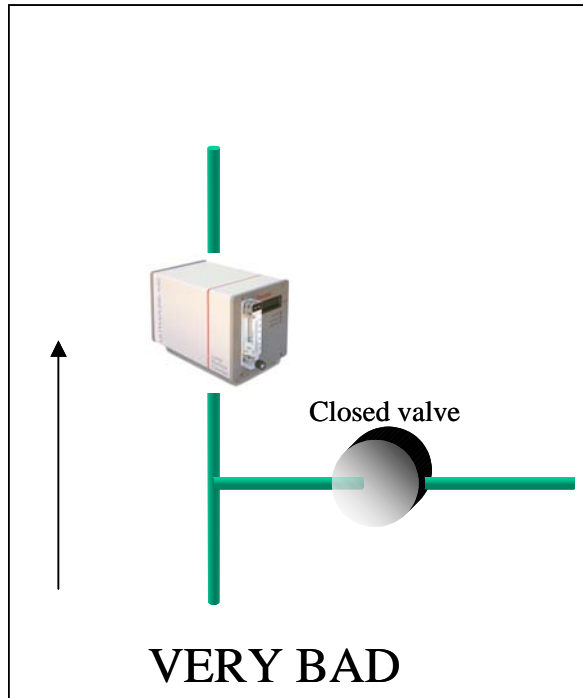

Fig C-4 : Stationary Flow in Dead Leg

Annex

Tables and illustrations

<i>Fig. 2-1</i>	<i>Front and Rear Panel Layouts</i>	10
<i>Fig. 2-2</i>	<i>Base Panel Layout (Base Cover Removed)</i>	11
<i>Fig. 3-1</i>	<i>Cable Cover</i>	15
<i>Fig. 3-2</i>	<i>4-20 mA Connector Header</i>	15
Table 3-1	Format of Data Shown by the Ultrapure-100.....	17
Table 3-2	4-20 mA Analog Output Specification	18
<i>Fig. 3-3</i>	<i>Ultrapure-100 Setup Utility Program, Setting Screen</i>	19
<i>Fig. 3-4</i>	<i>Utility Program Data Screen</i>	20
Table 3-3	Troubleshooting Diagnostics	21
<i>Fig. 4-1</i>	<i>Connector Pin-outs</i>	23
Table 4-1	4-20 mA Specifications.....	23
Table 4-2	Scaling Equations.....	24
Table 4-3	Log Mode Data.....	24
<i>Fig. 4-2</i>	<i>4-20 mA Response in Log mode</i>	25
Table 4-4	Setup Utility Parameters.....	25
<i>Fig. 4-3</i>	<i>4-20 mA Response in Linear Mode</i>	26
Table 5-1	Command Set	28
Table 6-1	Initialization Sequence (After Power-up of the Ultrapure-100)	31
Table 6-2	Running Sequence.....	31
<i>Fig. 6-1</i>	<i>Data Output Format</i>	31
Table 7-1	Configuring CountSpec Software for a Job	33
<i>Fig. B-1</i>	<i>Safety Warning Labels</i>	40
<i>Fig. C-1</i>	<i>Examples of Good and Bad Tee Piece Placement</i>	43
<i>Fig. C-2</i>	<i>Examples of Good and Bad Multiport Valve Placement</i>	44
<i>Fig. C-3</i>	<i>Examples of Good and Bad Regulator Placement</i>	44
<i>Fig. C-4</i>	<i>Stationary Flow in Dead Leg</i>	45



Electrical equipment marked with this symbol may not be disposed of in European public disposal systems after 12 August of 2005. In conformity with European local and national regulations (EU Directive 2002/96/EC), European electrical equipment users must now return old or end-of life equipment to the Producer for disposal at no charge to the user. *Note: For return for recycling, please contact the equipment producer or supplier for instructions on how to return end-of-life equipment for proper disposal.* Important document. Retain with product records.

GERMAN Elektrogeräte, die mit diesem Symbol gekennzeichnet sind, dürfen in Europa nach dem 12. August 2005 nicht mehr über die öffentliche Abfallentsorgung entsorgt werden. In Übereinstimmung mit lokalen und nationalen europäischen Bestimmungen (EU-Richtlinie 2002/96/EC), müssen Benutzer von Elektrogeräten in Europa ab diesem Zeitpunkt alte bzw. zu verschrottende Geräte zur Entsorgung kostenfrei an den Hersteller zurückgeben. *Hinweis: Bitte wenden Sie sich an den Hersteller bzw. an den Händler, von dem Sie das Gerät bezogen haben, um Informationen zur Rückgabe des Altgeräts zur ordnungsgemäßen Entsorgung zu erhalten.* Wichtige Informationen. Bitte zusammen mit den Produktinformationen aufbewahren.

FRENCH A partir du 12 août 2005, il est interdit de mettre au rebut le matériel électrique marqué de ce symbole par les voies habituelles de déchetterie publique. Conformément à la réglementation européenne (directive UE 2002/96/EC), les utilisateurs de matériel électrique en Europe doivent désormais retourner le matériel usé ou périmé au fabricant pour élimination, sans frais pour l'utilisateur. *Remarque : Veuillez vous adresser au fabricant ou au fournisseur du matériel pour les instructions de retour du matériel usé ou périmé aux fins d'élimination conforme.* Ce document est important. Conservez-le dans le dossier du produit.

ITALIAN Le apparecchiature elettriche con apposto questo simbolo non possono essere smaltite nelle discariche pubbliche europee successivamente al 12 agosto 2005. In conformità alle normative europee locali e nazionali (Direttiva UE 2002/96/EC), gli utilizzatori europei di apparecchiature elettriche devono restituire al produttore le apparecchiature vecchie o a fine vita per lo smaltimento senza alcun costo a carico dell'utilizzatore. *Nota: Per conoscere le modalità di restituzione delle apparecchiature a fine vita da riciclare, contattare il produttore o il fornitore dell'apparecchiatura per un corretto smaltimento.* Documento importante. Conservare con la documentazione del prodotto.

DANISH Elektriske apparater, der er mærket med dette symbol, må ikke bortskaffes i europæiske offentlige affaldssystemer efter den 12. august 2005. I henhold til europæiske lokale og nationale regler (EU-direktiv 2002/96/EF) skal europæiske brugere af elektriske apparater nu returnere gamle eller udtjente apparater til producenten med henblik på bortskaffelse uden omkostninger for brugeren. *Bemærk: I forbindelse med returnering til genbrug skal du kontakte producenten eller leverandøren af apparatet for at få instruktioner om, hvordan udtjente apparater bortskaffes korrekt.* Vigtigt dokument. Opbevares sammen med produktdokumenterne.

SWEDISH Elektronikutrustning som är märkt med denna symbol kanske inte kan lämnas in på europeiska offentliga sopstationer efter 2005-08-12. Enligt europeiska lokala och nationella föreskrifter (EU-direktiv 2002/96/EC) måste användare av elektronikutrustning i Europa nu återlämna gammal eller utstrangerad utrustning till tillverkaren för kassering utan kostnad för användaren. *Obs! Om du ska återlämna utrustning för återvinning ska du kontakta tillverkaren av utrustningen eller återförsäljaren för att få anvisningar om hur du återlämnar kasserad utrustning för att den ska bortskaffas på rätt sätt.* Viktigt dokument. Spara tillsammans med dina produktbeskrivningar.

SPANISH A partir del 12 de agosto de 2005, los equipos eléctricos que lleven este símbolo no deberán ser desechados en los puntos limpios europeos. De conformidad con las normativas europeas locales y nacionales (Directiva de la UE 2002/96/EC), a partir de esa fecha, los usuarios europeos de equipos eléctricos deberán devolver los equipos usados u obsoletos al fabricante de los mismos para su reciclado, sin coste alguno para el usuario. *Nota: Sírvase ponerse en contacto con el fabricante o proveedor de los equipos para solicitar instrucciones sobre cómo devolver los equipos obsoletos para su correcto reciclado.* Documento importante. Guardar junto con los registros de los equipos.

DUTCH Elektrische apparatuur die is voorzien van dit symbool mag na 12 augustus 2005 niet meer worden afgevoerd naar Europese openbare afvalsystemen. Conform Europese lokale en nationale wetgeving (EU-richtlijn 2002/96/EC) dienen gebruikers van elektrische apparaten voortaan hun oude of afgedankte apparatuur kosteloos voor recycling of vernietiging naar de producent terug te brengen. *Nota: Als u apparatuur voor recycling terugbrengt, moet u contact opnemen met de producent of leverancier voor instructies voor het terugbrengen van de afgedankte apparatuur voor een juiste verwerking.* Belangrijk document. Bewaar het bij de productpapieren.

POLISH Sprzęt elektryczny oznaczony takim symbolem nie może byćlikwidowany w europejskich systemach utylizacji po dniu 12 sierpnia 2005. Zgodnie z europejskimi, lokalnymi i państwowymi przepisami prawa (Dyrektywa Unii Europejskiej 2002/96/EC), użytkownicy sprzętu elektrycznego w Europie muszą obecnie przekazywać Producentowi stary sprzęt lub sprzęt po okresie użytkowania do bezpłatnej utylizacji. *Uwaga: Aby przekazać sprzęt do recyklingu, należy zwrócić się do producenta lub dostawcy sprzętu w celu uzyskania instrukcji dotyczących procedur przekazywania do utylizacji sprzętu po okresie użytkowania.* Ważny dokument. Zachować z dokumentacją produktu.

PORTUGUESE Qualquer equipamento eléctrico que ostente este símbolo não poderá ser eliminado através dos sistemas públicos europeus de tratamento de resíduos sólidos a partir de 12 de Agosto de 2005. De acordo com as normas locais e europeias (Directiva Europeia 2002/96/EC), os utilizadores europeus de equipamentos eléctricos deverão agora devolver os seus equipamentos velhos ou em fim de vida ao produtor para o respectivo tratamento sem quaisquer custos para o utilizador. *Nota: No que toca à devolução para reciclagem, por favor, contacte o produtor ou fornecedor do equipamento para instruções de devolução de equipamento em fim de vida para a sua correcta eliminação.* Documento importante. Mantenha junto dos registos do produto.

Global Headquarters

6, route de Compois C.P. 212
CH-1222 Vesenaz, Geneva, Switzerland
Tel +41 (0)22 594 64 00
Fax +41 (0)22 594 64 99

Americas Headquarters

481 California Avenue
Grants Pass, Oregon 97526 USA
Tel 1 800 866 7889 / +1 541 472 6500
Fax +1 541 472 6170

www.hachultra.com

